

# A NONLINEAR VISION BASED TRACKING SYSTEM FOR COORDINATED CONTROL OF MARINE VEHICLES

P. Oliveira <sup>\*,1</sup> A. Pascoal <sup>\*,1</sup> I. Kaminer <sup>\*\*</sup>

*\* IST/DEEC and Institute for Systems and Robotics,  
Av. Rovisco Pais, 1049-001 Lisboa, Portugal*

*\*\* Naval Postgraduate School, Monterey, CA 93943, USA*

Abstract: A nonlinear vision based tracking system is developed to provide estimates of the position and velocity of an Autonomous Underwater Vehicle (AUV) relative to an Autonomous Surface Craft (ASC). Nonlinear estimator design builds on the theory of linear parametrically varying (LPV) systems. The theoretical framework adopted provides a powerful tool for estimator regional stability and performance analysis. Simulations illustrate the performance of the tracker developed.

Keywords: Nonlinear Filters, LPVs, Autonomous Vehicles, Vision Systems

## 1. INTRODUCTION

In recent years there has been increasing interest in the use of fleets of autonomous vehicles to perform complex missions. Air, land, and sea examples of such cooperative missions can be found in (SEMA, 2000) and the references therein. See also (Pascoal *et al.*, 2000; ASIMOV, 1998-1999) for an example of cooperative motion control of the DELFIM Autonomous Surface Craft (ASC) and the INFANTE Autonomous Underwater Vehicle (AUV) for marine science applications.

In the latter case, data exchange between the two vehicles must rely on acoustic communications due to the strong attenuation experienced by electromagnetic waves in the water. In order to have access to higher bandwidth acoustic communications, the vertical channel must be used. This constraint motivated the design of joint cooperative missions where the ASC Delfim is positioned in a vicinity of the vertical position of the AUV

Infante with minimal exchange of navigation data between the two platforms (Pascoal *et al.*, 2000).

These requirements led naturally to the problem of implementing a tracker on board the ASC to provide estimates of the relative position and velocity of both platforms. The paper proposes a structure for the tracker that complements data from a camera with that available from other motion sensors. This solution is plausible in shallow water and under high visibility conditions, when an artificial feature associated with the AUV can be extracted from the image obtained on board the ASC.

The key contribution of this paper is the development of a vision based nonlinear tracker that departs considerably from classical solutions. The methodology developed for system design builds on the theory of Linear Parametrically Varying (LPV) Systems (Scherer, 2000), which are shown to provide a new powerful framework for the design of navigation filters for autonomous vehicles that rely on inertial and vision sensors. The new methodology leads to filter structures that are intuitively appealing. Furthermore, it provides tools to assess regional (non-local) stability and performance.

---

<sup>1</sup> Research supported in part by the EC under the research network FREESUB and by the Portuguese FCT under project MAROV of the PDCTM Programme.

## 2. MATHEMATICAL BACKGROUND

This section introduces some technical results for the study of linear parametrically varying (LPV) systems as a special case of linear time-varying systems. The notation and the basic theory are by now standard, see (Becker and Packard, 1994), (Boyd *et al.*, 1994), (Green and Limebeer, 1995), (Scherer, 2000) and (Vidyasagar, 1985).

Let  $\mathcal{Q}$  (a compact subset of  $\mathcal{R}^p$ ) denote a parameter variation set and let  $\mathcal{F}_\rho$  be the set of all continuous functions mapping  $\mathcal{R}^+$  to  $\mathcal{Q}$ . We will restrict ourselves to the class of LPV systems  $\mathcal{G}_{\mathcal{F}_\rho}$  with finite-dimensional state-space realizations

$$\Sigma_{\mathcal{G}_{\mathcal{F}_\rho}} = \begin{cases} \dot{\mathbf{x}} = A(\rho(t))\mathbf{x} + B(\rho(t))\mathbf{w}, \\ \mathbf{z} = C(\rho(t))\mathbf{x} \end{cases} \quad (1)$$

where  $\rho \in \mathcal{F}_\rho$ ,  $\mathbf{x} \in \mathbb{R}^n$  is the state,  $\mathbf{w} \in \mathcal{W} = \mathbb{R}^m$  is the input, and  $\mathbf{z} \in \mathcal{Z} = \mathbb{R}^p$  is the system output. The symbols  $A(\rho(t))$ ,  $B(\rho(t))$ , and  $C(\rho(t))$  denote matrices of bounded, piecewise continuous functions of time, depending on a continuous time-varying parameter  $\rho(t)$  of proper dimensions. See (Becker and Packard, 1994; Boyd *et al.*, 1994; Scherer, 2000) and references therein for an introduction to the subject. In an LPV system the parameter  $\rho \in \mathcal{F}_\rho$  is assumed to be unknown but measurable online. Note that the symbol  $\mathcal{G}_{\mathcal{F}_\rho}$  denotes both an LPV system and its particular realization  $\Sigma_{\mathcal{G}_{\mathcal{F}_\rho}}$ , as the meaning will become clear from the context.

An LPV system  $\mathcal{G}_{\mathcal{F}_\rho} : L_2 \rightarrow L_2$  is said to be stable if its  $\mathcal{L}_2$  induced operator norm

$$\|\mathcal{G}_{\mathcal{F}_\rho}\|_{2,i} = \sup_{\rho \in \mathcal{Q}} \sup_{\mathbf{w} \in L_2, \|\mathbf{w}\|_2 \neq 0} \left\{ \frac{\|\mathcal{G}_\rho \mathbf{w}\|_2}{\|\mathbf{w}\|_2} \right\} \quad (2)$$

is well defined and finite. The following result is instrumental in computing the  $\mathcal{L}_2$  induced operator norm of a system.

*Theorem 2.1.* Consider the LPV system  $\mathcal{G}_{\mathcal{F}_\rho} : \mathcal{W} \rightarrow \mathcal{Z}$  with realization (1). Suppose there exists a positive definite, symmetric matrix  $X \in \mathbb{R}^{n \times n}$  such that for all  $\rho \in \mathcal{Q}$  the matrix inequality  $A^T(\rho(t))X + XB(\rho(t))B^T(\rho(t))X + XA(\rho(t)) + \frac{C(\rho(t))C^T(\rho(t))}{\gamma^2} < 0$  holds. Then, for  $x(0) = 0$ ,  $w \in L_2$ ,  $\|w\|_2 < 1$  and  $\forall \rho \in \mathcal{Q}$ ,  $\lim_{t \rightarrow \infty} x(t) = 0$  and  $\|\mathcal{G}_{\mathcal{F}_\rho}\|_{2,i} < \gamma$ .

The extension of these definitions to the case where the operator inputs and outputs belong to the space of essentially bounded functions of time is immediate. A system  $\mathcal{G}_{\mathcal{F}_\rho} : \mathcal{L}_2 \rightarrow \mathcal{L}_\infty$  described by equation (2) is said to be finite-gain stable if its  $\|\mathcal{G}_{\mathcal{F}_\rho}\|_{2,\infty}$  induced norm defined as

$$\|\mathcal{G}_{\mathcal{F}_\rho}\|_{2,\infty} = \sup_{\rho \in \mathcal{Q}} \sup_{\mathbf{w} \in L_2, \|\mathbf{w}\|_2 \neq 0} \left\{ \frac{\|\mathcal{G}_\rho \mathbf{w}\|_\infty}{\|\mathbf{w}\|_2} \right\} \quad (3)$$

is well defined and finite. The  $\mathcal{G}_{\mathcal{F}_\rho, 2,\infty}$  induced norm is also referred to as the generalized  $\mathcal{H}_2$  norm.

Equipped with this set of results the tracking problem will be formulated and a solution proposed and analyzed.

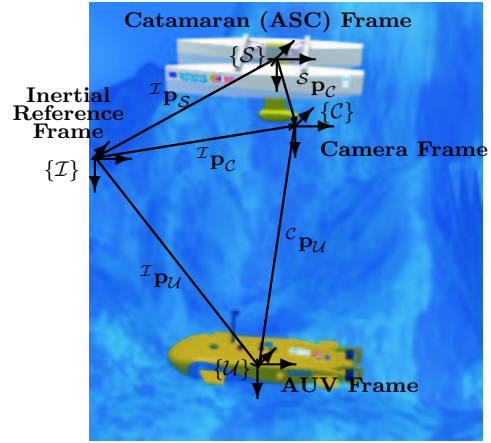

Fig. 1. Reference frames and notation.

## 3. TRACKER DESIGN. MOTIVATION AND DESIGN MODEL

This section describes the tracker problem which is the main focus of this paper.

### 3.1 Notation

Let  $\{\mathcal{I}\}$  be an inertial reference frame located in the pre-specified mission scenario origin, at mean sea level, and let  $\{\mathcal{S}\}$  and  $\{\mathcal{U}\}$  denote body-fixed frames that move with the ASC and the AUV, respectively, as depicted in figure 1. The following notation is required:

- ${}^{\mathcal{I}}\mathbf{p}_S$  - position of the origin of  $\{\mathcal{S}\}$  in  $\{\mathcal{I}\}$ ;
- ${}^{\mathcal{I}}\mathbf{p}_U$  - position of the origin of  $\{\mathcal{U}\}$  in  $\{\mathcal{I}\}$ ;
- $\mathbf{p}$  - position of the origin of  $\{\mathcal{U}\}$  relative to  $\{\mathcal{S}\}$ , expressed in  $\{\mathcal{I}\}$ , i.e.,  $\mathbf{p} = {}^{\mathcal{I}}\mathbf{p}_U - {}^{\mathcal{I}}\mathbf{p}_S$ ;
- ${}^{\mathcal{I}}\mathbf{v}_S$  - linear velocity of the origin of  $\{\mathcal{S}\}$  in  $\{\mathcal{I}\}$ ;
- ${}^{\mathcal{I}}\mathbf{v}_U$  - linear velocity of the origin of  $\{\mathcal{U}\}$  in  $\{\mathcal{I}\}$ ;
- $\boldsymbol{\lambda} := [\phi \ \theta \ \psi]^T$  - vector of roll, pitch, and yaw angles that parameterize locally the orientation of frame  $\{\mathcal{S}\}$  with respect to  $\{\mathcal{I}\}$ ;

### 3.2 Vehicles kinematics and the sensor suite

Given two frames  $\{\mathcal{A}\}$  and  $\{\mathcal{B}\}$ ,  ${}^{\mathcal{A}}\mathcal{R}$  denotes the rotation matrix from  $\{\mathcal{B}\}$  to  $\{\mathcal{A}\}$ . In particular,  ${}^{\mathcal{I}}\mathcal{R}(\boldsymbol{\lambda})$  is the rotation matrix from  $\{\mathcal{S}\}$  to  $\{\mathcal{I}\}$ , parameterized locally by  $\boldsymbol{\lambda}$ . Since  $\mathcal{R}$  is a rotation matrix, it satisfies the orthogonality condition  $\mathcal{R}^T = \mathcal{R}^{-1}$  that is,  $\mathcal{R}^T \mathcal{R} = I$ . It is well known (Britting, 1971) that

$$\frac{d}{dt} {}^{\mathcal{I}}\mathbf{p}_S = {}^{\mathcal{I}}\mathbf{v}_S = {}^{\mathcal{I}}\mathcal{R}(\boldsymbol{\lambda}) {}^{\mathcal{S}}({}^{\mathcal{I}}\mathbf{v}_S) \quad (4)$$

where  ${}^{\mathcal{S}}({}^{\mathcal{I}}\mathbf{v}_S)$  is the ASC velocity relative to the inertial frame, expressed in  $\mathcal{S}$  (i.e., body fixed velocity).

It is assumed that the ASC is equipped with a set of sensors and its own navigation system, as described in (ASIMOV, 1998-1999). The navigation system provides estimates  ${}^{\mathcal{I}}\mathbf{p}_S$  and  ${}^{\mathcal{I}}\mathbf{v}_S$  of the position and velocity of the body fixed frame  $\{\mathcal{S}\}$  relative to the inertial frame  $\{\mathcal{I}\}$ , respectively.

Estimates for the attitude  $\lambda$  are also available and, as a consequence,  ${}^{\mathcal{I}}\mathcal{R}(\lambda)$  is assumed to be known.

The tracker design problem at hand will be cast in a structure similar to a complementary filter (see (Oliveira, 2001)), based on measurements from a set of sensors installed on board. The sensor suite to be used and the available measurements will be discussed in the following. A video camera pointing down, able to discriminate some artificial feature of the AUV such as a strobe light, will be installed on board the ASC. The camera position  ${}^{\mathcal{I}}\mathbf{p}_C$  and its orientation  ${}^{\mathcal{I}}\mathcal{R}$  are given by (see figure 1)

$${}^{\mathcal{I}}\mathbf{p}_C = {}^{\mathcal{I}}\mathbf{p}_S + {}^{\mathcal{I}}\mathcal{R}(\lambda) {}^S\mathbf{p}_C \quad (5)$$

and  ${}^{\mathcal{I}}\mathcal{R}(\lambda) = {}^{\mathcal{I}}\mathcal{R}(\lambda) {}^S\mathcal{R}$  respectively where the dependence of the position  ${}^S\mathbf{p}_C$  and orientation  ${}^S\mathcal{R}$  on the sensor installation procedure is obvious. The coordinates of the AUV in the  $\{\mathcal{I}\}$  and  $\{\mathcal{C}\}$  frames can be related by

$${}^{\mathcal{I}}\mathbf{p}_U = {}^{\mathcal{I}}\mathbf{p}_C + {}^{\mathcal{I}}\mathcal{R}(\lambda) {}^C\mathbf{p}_U. \quad (6)$$

Using the relations (5) and (6), the coordinates of  $\{U\}$  in the camera frame  $\{\mathcal{C}\}$  are  ${}^C\mathbf{p}_U = {}^C\mathcal{R} {}^S\mathcal{R}(\lambda) ({}^{\mathcal{I}}\mathbf{p}_U - {}^{\mathcal{I}}\mathbf{p}_S - {}^{\mathcal{I}}\mathcal{R}(\lambda) {}^S\mathbf{p}_C)$ . Assuming without loss of generality that  ${}^C\mathcal{R} = I$  and  ${}^S\mathbf{p}_C = 0$ , this relation degenerates into

$${}^C\mathbf{p}_U = [x_c \ y_c \ z_c]^T = {}^C\mathcal{R}(\lambda) ({}^{\mathcal{I}}\mathbf{p}_U - {}^{\mathcal{I}}\mathbf{p}_S), \quad (7)$$

which can be written in compact form as  ${}^C\mathbf{p} = {}^C\mathcal{R}(\lambda) \mathbf{p}$ . Setting an artificial feature coincident with the origin of  $\{U\}$  (such as a strobe light), processing of the video images (i.e., threshold detection) can be used to extract its 2D coordinates

$$\begin{bmatrix} u_c \\ v_c \end{bmatrix} = \begin{bmatrix} f x_c / z_c \\ f y_c / z_c \end{bmatrix}, \quad (8)$$

on the image plane, where  $f$  is the focal distance for the pinhole model of the imaging system. This key relation in the computer vision area (Horn, 1985) corresponds to a nonlinear mapping from  $\mathcal{R}^3$  to  $\mathcal{R}^2$ , leading to an ambiguity in the coordinate measurements in the image plane. To solve this ambiguity, an additional measurement related to the AUV position is required, such as its depth or the distance between the two vehicles. In what follows we assume a depth cell is used. Assuming the ASC is at depth zero, the relative  $z$  coordinate (which equals the AUV depth) is obtained from the third row of equation (7) as

$$z = -s(\theta)x_c + c(\theta)s(\phi)y_c + c(\theta)c(\phi)z_c, \quad (9)$$

where  $s(\cdot)$  and  $c(\cdot)$  are the trigonometric sinus and co-sinus functions, respectively. This relation assumes that wave effects can be identified and removed from the equations due to the existence of a navigation system on board the ASC.

In order to implement the desired estimator structure, the complementary measurement of the AUV velocity relative to the ASC is required. A sensor that would measure this relative velocity, based on the Doppler effect experienced by acoustic waves travelling between the two vehicles, would be a possibility. However, this option requires sensors that are expensive or difficult

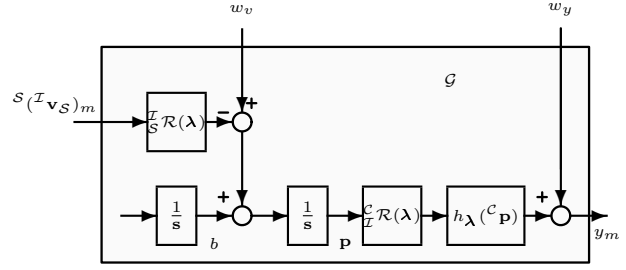

Fig. 2. Estimator model.

to implement and will therefore not be used in the proposed framework. Instead, an approximate relation that is introduced next will be exploited along this work. The relationship builds on the assumption that the AUV travels at constant velocity.

Consider the position of the AUV relative to the ASC (as depicted in figure 1), written as  ${}^{\mathcal{I}}\mathbf{p}_U = {}^{\mathcal{I}}\mathbf{p}_S + {}^{\mathcal{I}}\mathcal{R}(\lambda) {}^C\mathbf{p}$ , where  ${}^C\mathbf{p}$  is the relative position expressed in the camera frame  $\{\mathcal{C}\}$ . The velocities of both platforms can be related as  ${}^{\mathcal{I}}\mathbf{v}_U = {}^{\mathcal{I}}\mathbf{v}_S + \frac{d}{dt}({}^{\mathcal{I}}\mathcal{R}({}^C\mathbf{p}))$ . Consider for the time being that the velocity of the AUV is zero (this restriction will be lifted shortly). Then,  $\frac{d}{dt}({}^{\mathcal{I}}\mathcal{R}({}^C\mathbf{p})) = -{}^{\mathcal{I}}\mathbf{v}_S$ , i.e., the velocity of the AUV as seen by the ASC and expressed in the inertial frame  $\{\mathcal{I}\}$  is, apart from a change in signal, the same as the velocity of the catamaran in  $\{\mathcal{I}\}$ . Moreover, using the fact that a Doppler log is installed on board the ASC, this relation can be rewritten using (4) as  $\frac{d}{dt}({}^{\mathcal{I}}\mathcal{R}({}^C\mathbf{p})) = -{}^{\mathcal{I}}\mathcal{R}(\lambda) {}^S({}^{\mathcal{I}}\mathbf{v}_S)$ .

The assumption above motivates the use of an estimator with a bank of integrators aimed at estimating biases in the velocity measurements. The estimated biases corresponds to the deviation in the estimated ASC velocity due to the actual AUV velocity, which is different from zero.

### 3.3 Design model

In the following, the underlying design model that plays a central role in the design of the tracker is presented. The model is based on the kinematic relations presented above. The resulting model  $\mathcal{G}$  has the realization

$$\Sigma_{\mathcal{G}} = \begin{cases} \dot{\mathbf{p}} &= -{}^{\mathcal{I}}\mathcal{R}(\lambda) {}^S({}^{\mathcal{I}}\mathbf{v}_S)_m + b + w_v \\ \dot{b} &= 0 \\ y_m &= h_{\lambda}({}^C\mathbf{p}) + w_y, \end{cases} \quad (10)$$

where  $y_m$  is the measurement of  $y = [u_c \ v_c \ z]^T$ , i.e., the column vector of the variables from the sensors' measurements and  $h_{\lambda}({}^C\mathbf{p}) : \mathcal{R}^3 \rightarrow \mathcal{R}^3$  is obtained by putting together relations (8) and (9) for the camera model and depth measurement, respectively. Vector  $b$  denotes velocity bias that must be estimated. The velocity of the ASC is considered as an input to the model. The overall model structure is depicted in the block diagram of figure 2.

#### 4. TRACKER DESIGN AND ANALYSIS

The problem at hand can be described as that of determining estimates of the relative position and velocity of the AUV with respect to the ASC, based on the sensor package described before. The filter design model is the one in figure 2. In this section, a structure for a nonlinear estimator is proposed and analyzed.

Consider that the orientation of the camera frame installed on board the ASC is constrained to be in the compact set given by

$$\Lambda_c = \{\lambda : |\phi| \leq \phi_{max}, |\theta| \leq \theta_{max}\}, \quad (11)$$

and that the relative position of the AUV relative to the ASC, expressed in  $\{\mathcal{C}\}$ , is constrained to be in

$$\mathcal{P}_c = \left\{ {}^c\mathbf{p} = [x_c \ y_c \ z_c]^T : \begin{array}{l} \underline{x} \leq x_c \leq \bar{x}, \\ \underline{y} \leq y_c \leq \bar{y}, \\ 0 < \underline{z} \leq z_c \leq \bar{z} \end{array} \right\}. \quad (12)$$

Notice that the yaw angle  $\psi$  is not constrained,  $\underline{x} \dots \bar{z}$  can be chosen according to the mission scenario and the expected vehicles dynamics, and  $z_c$  is positive given the fact that we are dealing with an underwater vehicle and the inertial frame origin  $\{\mathcal{I}\}$  is located at mean sea level. Let the estimates of the relative position  ${}^c\mathbf{p}$  and velocity  $\mathbf{v}$  be written as  $\hat{\mathbf{p}}_c$  and  $\hat{\mathbf{v}}_c$ , respectively. It will be required that the relative position estimate  ${}^c\hat{\mathbf{p}}$  lie in the compact set

$$\hat{\mathcal{P}}_c = \left\{ {}^c\hat{\mathbf{p}} : \begin{array}{l} |\hat{x}_c - x_c| \leq \bar{x} - \underline{x} + dx, \\ |\hat{y}_c - y_c| \leq \bar{y} - \underline{y} + dy, \\ |\hat{z}_c - z_c| \leq \bar{z} - \underline{z} + dz \end{array} \right\}, \quad (13)$$

where  $dx$ ,  $dy$ , and  $dz$  are positive numbers and  $dz < \underline{z}$ .

The estimator structure proposed in this paper builds on a key result that was introduced in (Rizzi and Koditschek, 1996). See also (Kaminer *et al.*, 1999), where the same structure is used in a navigation system for automatic landing of autonomous aircraft. This algebraic result, which relates errors in the image plane with errors observed in the inertial frame, is stated in the following lemma:

*Lemma 4.1.* Let  $h_\lambda(\dots)$  be the mapping function introduced in section 3. Then

$$h_\lambda({}^c\hat{\mathbf{p}}) - h_\lambda({}^c\mathbf{p}) = L({}^c\hat{\mathbf{p}}, {}^c\mathbf{p})H({}^c\hat{\mathbf{p}})({}^c\hat{\mathbf{p}} - {}^c\mathbf{p}), \quad (14)$$

where  $L({}^c\hat{\mathbf{p}}, {}^c\mathbf{p}) = \text{diag}(\hat{z}_c/z_c, \hat{z}_c/z_c, 1)$  and  $H({}^c\hat{\mathbf{p}})$  denotes the Jacobian of  $h_\lambda({}^c\hat{\mathbf{p}})$ , with respect to  ${}^c\hat{\mathbf{p}}$ .

According to the definition of  $h_\lambda({}^c\hat{\mathbf{p}})$ , the Jacobian verifies  $|H({}^c\hat{\mathbf{p}})| = \hat{z}_c^3/z_c$ , therefore it is invertible in the compact set of positions where the missions will take place. As a motivation to the structure of the estimator to be proposed, invert expression (14) to obtain

$${}^c\hat{\mathbf{p}} - {}^c\mathbf{p} = H^{-1}({}^c\hat{\mathbf{p}})L^{-1}({}^c\hat{\mathbf{p}}, {}^c\mathbf{p})(h_\lambda({}^c\hat{\mathbf{p}}) - h_\lambda({}^c\mathbf{p})).$$

Assuming that  $\hat{z}_c/z_c \approx 1$  yields  $L({}^c\hat{\mathbf{p}}, {}^c\mathbf{p}) \approx I$ , i.e.,

$$({}^c\hat{\mathbf{p}} - {}^c\mathbf{p}) = H({}^c\hat{\mathbf{p}})^{-1}(h_\lambda({}^c\hat{\mathbf{p}}) - h_\lambda({}^c\mathbf{p})). \quad (15)$$

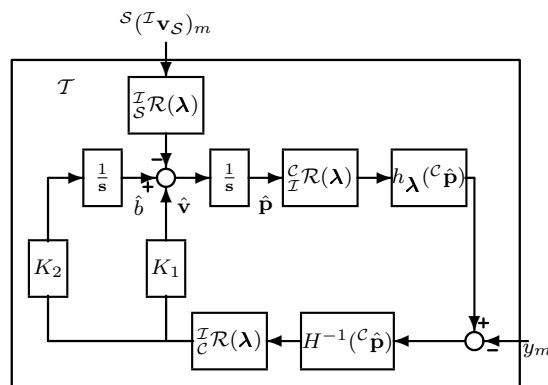

Fig. 3. Nonlinear tracker structure.

The importance of this nonlinear relation is twofold: i) it can be used in the estimator as a way to relate errors in the sensor measurements with state variable errors, and ii) it holds the key to bring the estimator dynamics into the form of a LPV system.

##### 4.1 Proposed solution

Motivated by the relation in (15), the solution proposed for the problem addressed in this paper is the tracker with realization

$$\Sigma_T = \begin{cases} \dot{\mathbf{p}} = \begin{array}{l} -\frac{\mathcal{I}}{S}\mathcal{R}(\lambda)^S(\mathcal{I}\mathbf{v}_S)_m + \hat{b} \\ + K_1 \frac{\mathcal{I}}{C}\mathcal{R}(\lambda)H^{-1}({}^c\hat{\mathbf{p}})(h_\lambda({}^c\hat{\mathbf{p}}) - y_m) \end{array} \\ \dot{\hat{b}} = K_2 \frac{\mathcal{I}}{C}\mathcal{R}(\lambda)H^{-1}({}^c\hat{\mathbf{p}})(h_\lambda({}^c\hat{\mathbf{p}}) - y_m), \end{cases} \quad (16)$$

where  $\hat{\mathbf{p}}$  is the relative position estimate,  $\hat{b}$  is the bias estimate, and  $K_1$  and  $K_2$  are gains to be computed so as to meet adequate stability and performance criteria. The estimator structure is depicted in figure 3. The input, state and output vectors are three dimensional. Clearly, this is an LPV system.

We now address the problems of regional stability and performance of the filter proposed, referred to as  $\mathbf{P}_1$  and  $\mathbf{P}_2$  respectively, below.

**$\mathbf{P}_1$  Regional Stability** - Consider the design model and the estimator structure introduced before. Further assume that  $w_v = w_y = 0$ . Given an envisioned mission scenario defined by  $\mathcal{P}_c$ , find a number  $\alpha > 0$  and observer parameters such that the estimates  $\hat{\mathbf{p}}$  of  $\mathbf{p}$  and  $\hat{\mathbf{v}}$  of  $\mathbf{v}$  verify the relationships

- a)  ${}^c\hat{\mathbf{p}} \in \hat{\mathcal{P}}_c$  for  $t > 0$ ,
- b)  $\|\hat{\mathbf{p}} - \mathbf{p}\| + \|\hat{\mathbf{v}} - \mathbf{v}\| \rightarrow 0$  as  $t \rightarrow \infty$  and whenever  $\|[(\hat{\mathbf{p}}(0) - \mathbf{p}(0))^T, (\hat{\mathbf{b}}(0) - \mathbf{b}(0))^T]^T\|_\infty < \alpha$ .

The next theorem gives conditions under which  $\mathbf{P}_1$  has a solution. The proof is omitted. See theorem 4.3 in (Kaminer *et al.*, 1999) for a similar result.

*Theorem 4.2.* Consider a mission scenario where the orientation and position variables are constrained by (11) and (12) respectively, and let  $\hat{\mathcal{P}}_c$  be given. Let  $\alpha < \min(\bar{x} - \underline{x} + dx, \bar{y} - \underline{y} + dy, \bar{z} - \underline{z} + dz)$  be a positive number and define  $r_z = \frac{\bar{z} - \underline{z} + dz}{\underline{z}} < 1$ . Further let  $F = \begin{bmatrix} 0 & I \\ 0 & 0 \end{bmatrix}$  and  $C = [I \ 0]$ . Suppose there exists a matrix  $P = P^T > 0 \in \mathcal{R}^{6 \times 6}$  such that

$$F^T P + P F + \begin{bmatrix} -2(1 - r_z)^2 I & 0 \\ 0 & 0 \end{bmatrix} < 0, \quad (17)$$

$$P - \max \left( \begin{array}{c} \frac{1}{(\bar{x} - \underline{x} + dx)^2}, \\ \frac{1}{(\bar{y} - \underline{y} + dy)^2}, \\ \frac{1}{(\bar{z} - \underline{z} + dz)^2} \end{array} \right) C^T C > 0, \quad (18)$$

$$\frac{I}{\alpha^2} - P > 0. \quad (19)$$

Then the filter with realization (16) and parameters  $K = [K_1^T \ K_2^T]^T = -P^{-1}(1 - r_z)C^T$  solves the filtering problem  $\mathbf{P}_1$ .

We now address the more complex problem of filter performance in the presence of sensor noise. Notice how filter performance is captured in terms of a bound on the induced norm of a suitably defined operator.

## $\mathbf{P}_2$ Regional Stability and Performance -

Consider a mission scenario defined by  $\mathcal{P}_c$  and  $\hat{\mathcal{P}}_c$  in (12). Consider also the design model (10), with  $w = [w_y^T \ w_v^T]^T \in L_2$  and  $\|w\|_2 < 1$ . Given positive numbers  $\gamma > 0$  and  $\alpha > 0$  find (if possible) the observer parameters such that

- $\|T_{ew}\|_{2,\infty} < \gamma$ , where  $\mathbf{e} = [(\hat{\mathbf{p}} - \mathbf{p})^T (\hat{\mathbf{b}} - \mathbf{b})^T]^T$  and  $T_{ew} : w \rightarrow \mathbf{e}$ ;
- ${}^c \hat{\mathbf{p}} \in \hat{\mathcal{P}}_c$  for  $t > 0$ ;
- $e(t) \rightarrow 0$  as  $t \rightarrow \infty$  when  $w = 0$  and  $\|[(\hat{\mathbf{p}}(0) - \mathbf{p}(0))^T, (\hat{\mathbf{b}}(0) - \mathbf{b}(0))^T]^T\|_\infty < \alpha$

The next theorem gives conditions under which  $\mathbf{P}_2$  has a solution.

*Theorem 4.3.* Consider a mission scenario where the orientation and position variables are constrained by (11) and (12) respectively, and let  $\hat{\mathcal{P}}_c$  be given. Let  $\alpha < \min(\bar{x} - \underline{x} + dx, \bar{y} - \underline{y} + dy, \bar{z} - \underline{z} + dz)$  be a positive number and define  $r_z = \frac{\bar{z} - \underline{z} + dz}{\underline{z}} < 1$ . Let  $\epsilon = \min_{\hat{\mathbf{p}}_c \in \hat{\mathcal{P}}_c} \lambda_{\max}(H({}^c \hat{\mathbf{p}})H^T({}^c \hat{\mathbf{p}}))$  and given  $\gamma$ , suppose there exists a matrix  $P = P^T > 0 \in \mathcal{R}^{6 \times 6}$  such that

$$\left[ \begin{array}{c|c} F^T P + \begin{bmatrix} \frac{I}{\gamma^2} & 0 \\ -(1 - r_z)^2(2 - \epsilon)I & 0 \end{bmatrix} & P F \\ \hline F^T P & -I \end{array} \right] < 0, \quad (20)$$

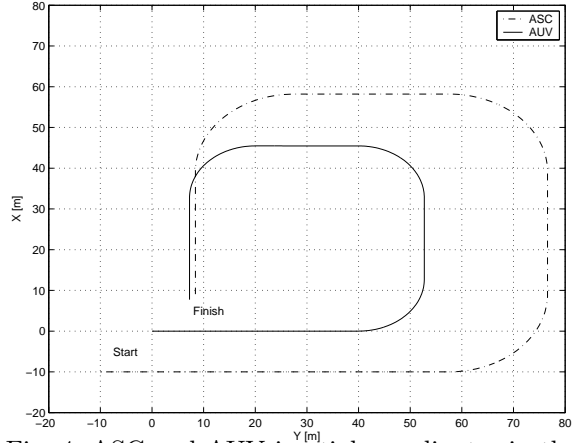

Fig. 4. ASC and AUV inertial coordinates in the horizontal plane.

$$P - 4 \max \left( \begin{array}{c} \frac{1}{(\bar{x} - \underline{x} + dx)^2}, \\ \frac{1}{(\bar{y} - \underline{y} + dy)^2}, \\ \frac{1}{(\bar{z} - \underline{z} + dz)^2} \end{array} \right) C^T C > 0, \quad (21)$$

$$\frac{I}{\alpha^2} - P > 0. \quad (22)$$

Then, the filter with realization (16) and parameters  $K = [K_1^T \ K_2^T]^T = -P^{-1}(1 - r_z)C^T$  solves problem  $\mathbf{P}_2$  if  $\|[(\hat{\mathbf{p}}(0) - \mathbf{p}(0))^T, (\hat{\mathbf{b}}(0) - \mathbf{b}(0))^T]^T\|_\infty < \alpha$ .

Theorems 4.2 and 4.3 provide the tools for the design and analysis of the proposed estimator with complementary filtering properties.

## 5. EXPERIMENTAL RESULTS

This section summarizes the design and analyzes briefly the performance of a non linear tracker with the structure proposed in (16) for a simulated mission scenario that requires the concerted operation of the AUV and the ASC.

The nominal trajectories performed by the ASC and the AUV are square shaped in the horizontal plane, with constant nominal velocities  ${}^S(\mathcal{I}\mathbf{v}_S) = [1.5 \ 0 \ 0]^T$  m/s and  ${}^U(\mathcal{I}\mathbf{v}_U) = [1.0 \ 0 \ 0]^T$  m/s, respectively. The ASC remains at the sea surface ( ${}^I z_s = 0$  m) and the AUV starts the mission at a depth of  ${}^I z_u = 30$  m. From time  $t = 60$  s until  $t = 80$  s the AUV changes its depth with a constant vertical velocity of  ${}^I \dot{z}_u = 0.25$  m/s.

The envisioned missions are naturally constrained by the ability of the video camera installed on board the ASC to detect artificial features on the AUV. This impacted on the choice of the parameters for the compact sets  $\mathcal{P}_c$  and  $\hat{\mathcal{P}}_c$ , as shown in table 1. The value of  $\gamma$  in Theorem 4.3 has a lower bound of  $\gamma^2 > 55.8$ , which is a lower bound on the induced norm  $\|T_{ew}\|_{(2,i)}$ .

From the LMIs introduced in theorems 4.2 and 4.3 and from the aforementioned parameters, the

	Parameter	Value
$\Lambda_c$	$\phi_{max}$	$5^\circ$
	$\theta_{max}$	$5^\circ$
$\mathcal{P}_c$	$\underline{x} = \underline{y}$	$-20\text{ m}$
	$\bar{x} = \bar{y}$	$20\text{ m}$
	$\underline{z}$	$20\text{ m}$
	$\bar{z}$	$38\text{ m}$
$\hat{\mathcal{P}}_c$	$dx$	$0.1\text{ m}$
	$dy$	$0.1\text{ m}$
	$dz$	$0.1\text{ m}$
Theorems 4.2 and 4.3	$\alpha$	$18.1\text{ m}$
	$r_z$	$0.905\text{ m}$
Theorem 4.3	$\epsilon$	$0.0132$

Table 1. Nonlinear tracker design parameters.

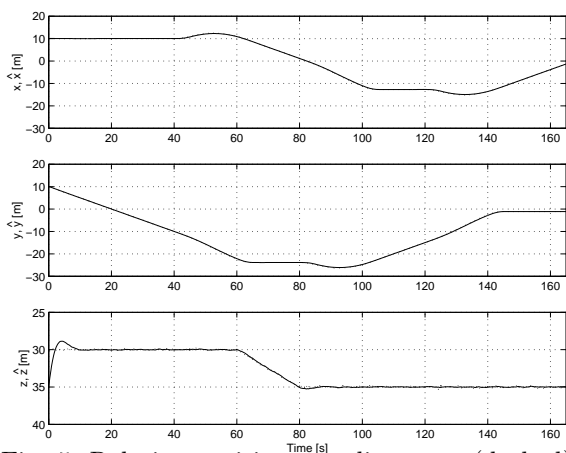

Fig. 5. Relative position coordinates  $\mathbf{p}$  (dashed) and estimates  $\hat{\mathbf{p}} = [\hat{x} \hat{y} \hat{z}]^T$ .

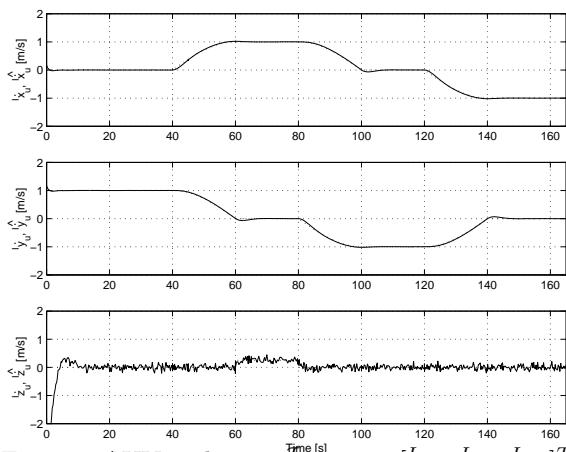

Fig. 6. AUV velocity  $\overset{\text{Time [s]}}{\mathbf{v}_u} = [I\dot{x}_u \ I\dot{y}_u \ I\dot{z}_u]^T$  (dashed) and estimates  $I\hat{\dot{x}}_u, I\hat{\dot{y}}_u$  and  $I\hat{\dot{z}}_u$ .

value for the estimator gains are  $K_1 = 0.74 I_{3 \times 3}$  and  $K_2 = 0.30 I_{3 \times 3}$ , respectively.

In the experiment, additive gaussian noise with zero mean and a standard deviation of  $0.1\text{ m}$  for the depth sensor was considered. The relative  $z$  coordinate was initialized at  $35\text{ m}$  when the nominal value was  $30\text{ m}$ . The results for the relative position  $\mathbf{p}$  are depicted in figure 5, which shows very small estimation errors. A stronger impact of depth sensor noise on the AUV vertical velocity estimate can be observed in figure 6, due to the structure of the estimator chosen. However,

the vertical velocity changes are still estimated reliably.

## 6. CONCLUSIONS

A nonlinear vision based tracking system was developed to provide estimates of the position and velocity of an Autonomous Underwater Vehicle (AUV) relative to an Autonomous Surface Craft (ASC). Future work will address the problem of tracker stability and performance in the presence of out of frame events that arise when the camera loses temporarily the target due to vehicle rolling and pitching.

## 7. REFERENCES

- ASIMOV (1998-1999). *Advanced System Integration for Managing the Coordinated Operation of Robotic Ocean Vehicles - ASIMOV*. Vol. 1-2. Technical Reports. ISR-IST, Lisbon, Portugal.
- Becker, G. and A. Packard (1994). Robust performance of linear, parametrically varying systems using parametrically dependent linear, dynamic feedback. *Systems and Control Letters* **23**, 205–215.
- Boyd, S., L. El Ghaoui, E. Feron and B. Balakrishnan (1994). *Linear Matrix Inequalities in Systems and Control Theory*. SIAM Studies in Applied Mathematics. Philadelphia.
- Britting, K. (1971). *Inertial Navigation System Analysis*. Wiley-Interscience.
- Green, M. and D. Limebeer (1995). *Linear Robust Control*. Prentice-Hall.
- Horn, B. (1985). *Robot Vision*. MIT Press. Cambridge, MA.
- Kaminer, I., A. Pascoal, W. Kang and O. Yakimenko (1999). Integrated vision/inertial navigation system design using nonlinear filtering. *Proceedings of the 1999 American Control Conference*.
- Oliveira, P. (2001). *Periodic and Non-linear Estimators with Applications to the Navigation of Ocean Vehicles*. PhD Thesis, Instituto Superior Técnico. ISR-IST, Lisbon, Portugal.
- Pascoal, A., P. Oliveira, C. Silvestre and et al (2000). Robotic ocean vehicles for marine science applications: the european asimov project. *MTS/IEEE Oceans 2000 Conference*.
- Rizzi, A. and D. Koditscheck (1996). An active visual estimator for dextrous manipulation. *IEEE Transactions on Robotics and Automation* **12**(5), 697–713.
- Scherer, C. (2000). *Linear Matrix Inequalities in Control*. Class notes.
- SEMA (2000). Special electronic mission aircraft (sema) conference.
- Vidyasagar, M. (1985). *Control System Synthesis: a Factorization Approach*. MIT Press.