

# Vehicle and Mission Control of Single and Multiple Autonomous Marine Robots

António Pascoal, Carlos Silvestre, Paulo Oliveira

Institute for Systems and Robotics (ISR) and Dept. Electrical Engineering and Computers,  
Instituto Superior Técnico (IST), Av. Rovisco Pais, 1 1049-001 Lisbon, Portugal

## 1. Introduction

The last decade has witnessed tremendous progress in the development of marine technologies that provide scientists with advanced equipment and methods for ocean exploration and exploitation. Recent advances in marine robotics, sensors, computers, communications, and information systems are being applied to develop sophisticated technologies that will lead to safer, faster, and far more efficient ways of exploring the ocean frontier, especially in hazardous conditions. As part of this trend, there has been a surge of interest worldwide in the development of autonomous marine robots capable of roaming the oceans freely, collecting data at the surface of the ocean and underwater on an unprecedented scale. Representative examples are autonomous surface craft (ASC) and autonomous underwater vehicles (AUVs). The mission scenarios envisioned call for the control of single or multiple AUVs acting in cooperation to execute challenging tasks without close supervision of human operators. Furthermore, it should be possible for users who are not necessarily familiar with the technical details of marine robot development to do mission programming and mission execution tasks. Thus the need to push the development of methods for reliable vehicle and mission control of single and multiple autonomous marine robots.

The present chapter addresses the topics of marine vehicle and mission control from both a theoretical and a practical point of view. The presentation is rooted in practical developments and experiments carried out with the Delfim and Caravela ASCs, and the Infante and Sirene AUVs. Examples of mission scenarios with the above vehicles working alone or in cooperation set the stage for the main contents of the chapter. The missions described justify the four basic categories of theoretical control problems addressed in the text: vertical and horizontal plane control, pose control, trajectory tracking and path following, and coordinated motion control. Challenging topics in these areas and current research trends are discussed. For a selected number of representative problems, the linear and nonlinear control design techniques used to solve them are briefly summarized. Linear control design borrows from recent advances in gain-scheduling control theory and from the theory of Linear Matrix Inequalities (LMIs). Nonlinear control design builds on Lyapunov-based techniques and backstepping. Design examples and results of experimental tests at sea with the controllers developed are given. After covering the development of “time-driven” systems for vehicle control, the chapter then provides a brief overview of the “event-driven” systems that must be in place in order to perform mission programming and mission execution reliably, that is, mission control. The mission control systems developed at ISR/IST build on Petri Net theory and allow for programming single and multiple vehicle missions using graphical interfaces. The hardware and software tools used for distributed system implementation are described. Results of real missions with the Delfim ASC and the Infante AUV illustrate the performance of the systems developed.

## 2. Marine Vehicles

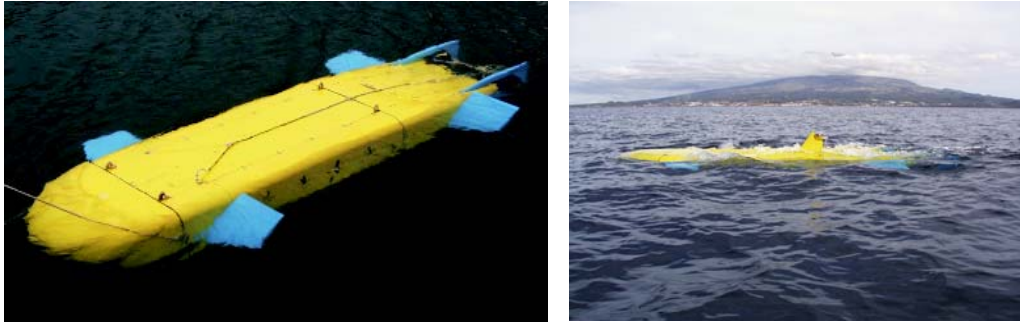

Figure 1. The Infante AUV. Left: vehicle being deployed;  
Right: vehicle at sea, in the Azores.

This section provides a brief description of representative marine vehicles that will be used to motivate mission scenarios and control design techniques in the chapter. The selection includes the Sirene and Infante autonomous underwater vehicles (AUVs) and the Delfim and Caravela autonomous surface craft (ASC). Except for Sirene, all the vehicles were designed and built by consortia of Portuguese companies and research institutes.

### 2.1 The INFANTE Autonomous Underwater Vehicle (AUV)

Figure 1 shows the Infante AUV, designed and built by the Instituto Superior Técnico through its Institute for Systems and Robotics. The AUV is the result of a major redesign of the Marius AUV (Egeskov et al. 1994, Pascoal et al. 1997), aimed at obtaining open loop vertical plane stability, increased maneuverability, and adequate performance even at low speeds. See (Asimov Team 2000, Silvestre 2000) and the references therein for descriptions of the vehicle and illustrative mission scenarios.

The vehicle is equipped with two stern thrusters for propulsion and six fully moving control surfaces (two stern rudders, two bow planes, and two stern planes) for vehicle steering and diving in the horizontal and vertical planes, respectively. The maximum rated speed of the vehicle with respect to the water is  $2.5m/s$ . At a cruising speed of  $1.3m/s$ , the estimated mission duration and range are  $18h$  and  $83km$ , respectively. The maximum depth of operation is  $500m$ . Its main particulars are as follows: length overall:  $4.5m$ ; beam of hull:  $1.1m$ ; beam overall, including bow and stern planes:  $2.0m$ ; draft of hull:  $0.6m$ ; frontal area:  $0.7m^2$ . Currently, its scientific sensor suite includes a Doppler log, a sidescan sonar, a mechanically scanning pencil beam sonar, a Conductivity-Temperature-Depth (CTD) recorder, a fluorometer, a Plankton sampler, and a video camera. In a representative mission, the vehicle performs lawn mowing maneuvers at different depths to collect scientific data in the water column. Given its good stability properties, the vehicle is also a good platform for maneuvering at a fixed depth and collecting acoustic data off the seabed for bathymetry mapping and sea-bottom classification purposes.

## 2.2 The DELFIM Autonomous Surface Craft (ASC)



Figure 2. The Delfim autonomous surface craft (ASC)

The Delfim is an autonomous surface craft (ASC) that was designed and built at the Instituto Superior Técnico. The research and development efforts that led to the development of Delfim were initiated in the scope of a European project that set the goal of achieving coordinated operation of an AUV and an ASC in order to establish a fast direct communication link between the two vehicles and thus indirectly between the AUV and a support vessel. This concept has proven instrumental in enabling the transmission of sonar and optical images through an acoustic communications channel optimized to transmit in the vertical. See (Asimov Team 2000) and the references therein for a brief description of the project and the major milestones achieved. Over the past few years, the Delfim ASC has also been used extensively as a stand-alone unit, capable of maneuvering autonomously and performing precise path following, while carrying out automatic marine data acquisition and transmission to an operating center installed on board a support vessel or on shore.

The DELFIM craft is a small Catamaran  $3.5m$  long and  $2.0m$  wide, with a mass of  $320kg$ , see Figure 2. Propulsion is ensured by two bladed propellers driven by electrical motors. The maximum speed of the vehicle with respect to the water is  $2.5m/s$ . The vehicle is equipped with on-board resident systems for navigation, guidance and control, and mission control. Navigation is done by integrating motion sensor data obtained from an attitude reference unit, a Doppler unit, and a DGPS (Differential Global Positioning System). Transmissions between the vehicle and its support vessel, or between the vehicle and a control center installed on-shore are achieved via a radio link with a range of  $80km$ . The vehicle has a wing shaped central structure that is lowered during operations at sea. Installed at the bottom of this structure is a low drag body that can carry acoustic transducers, including those used to communicate with submerged craft. For bathymetric operations, the wing is equipped with a mechanically scanning pencil beam sonar.

## 2.3 The Sirene Underwater Shuttle

The Sirene AUV is an underwater shuttle designed to automatically position a large range of benthic stations on the seabed down to depths of  $4000m$ . The vehicle and respective systems were developed by a team of European partners coordinated by



Figure 3. The Sirene underwater shuttle

IFREMER, in the scope of the MAST-II European project Desibel (New Methods for Deep Sea Intervention on Future Benthic Laboratories) that aimed to compare different methods for deploying and servicing benthic stations. The reader will find in (Brisset 1995), a general description of the Desibel project. See also (Aguiar 1997) for a theoretical study of the guidance and control systems of Sirene and (Oliveira 1998b) for a description of its mission control system.

The Sirene vehicle, shown in Figure 3, was designed as an open-frame structure 4.0m long, 1.6m wide, and 1.96m high. Its dry weight is 4000kg and its maximum operating depth is 4000m. The vehicle is equipped with two back thrusters for surge and yaw motion control in the horizontal plane, and one vertical thruster for heave control. Roll and pitch motion are left uncontrolled, since the metacentric height is sufficiently large (36cm) to provide adequate static stability. An acoustic link enables communications between the Sirene vehicle and a support ship for tele-operation purposes. At the core of the vehicle navigation system is a Long Baseline (LBL) positioning system developed by IFREMER (Brisset 1995). Sirene was designed as a prototype vehicle to transport and to accurately position benthic laboratories at pre-determined targets on the seabed. See Figure 4 (right), which depicts the vehicle carrying a representative benthic lab that is cube shaped and has a volume of  $2.3m^3$ . In a typical mission (Fig. 4, left) the Sirene vehicle and the laboratory are first coupled together and launched from a support ship. Then, the ensemble descends in a free-falling trajectory (under the action of a ballast weight) at a speed in the range of 0.5 to 1m/s.

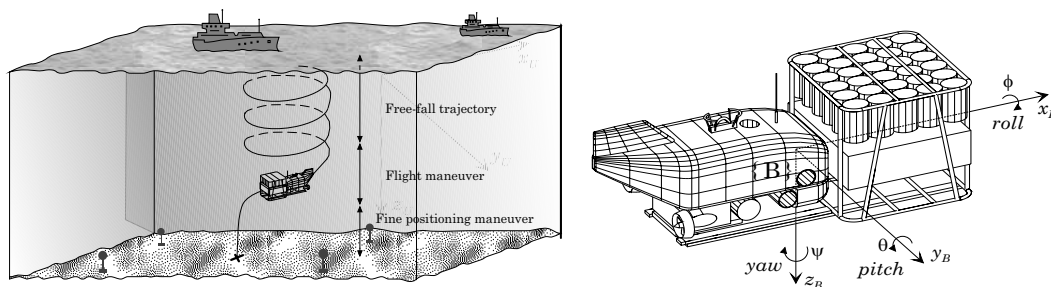

Figure 4. The Sirene underwater shuttle. Left: laboratory deployment mission; Right: the shuttle carrying a benthic laboratory.



Figure 5. The Caravela autonomous research vessel. Left: a scale model; Right: the vehicle hull in the shipyard.

At approximately 100m above the seabed, Sirene releases its ballast and the weight of the entire ensemble becomes neutral. At this point, the operator on board the support ship instructs the vehicle to progress at a fixed speed (along a path defined by a number of selected way-points) until it reaches a vicinity of the desired target point. At this point Sirene maneuvers to acquire the final desired heading and lands smoothly on target, after which it uncouples itself from the benthic laboratory and returns to the surface. Tests with the prototype vehicle were carried out off the coast of Toulon, France, in 1997.

#### 2.4 The Caravela 2000 Autonomous Research Vessel

The Caravela is a long range Autonomous Research Vessel developed by a consortium of industrial partners (Rinave and Conafi) and research institutes (IMAR and IST/ISR) in Portugal, under the scientific leadership of the IMAR/Department of Oceanography and Fisheries of the University of the Azores (Caravela 2001). Conceptually, the Caravela bears great likeness to the Delfim ASC in that it can operate in a fully autonomous mode without constant supervision of a human operator. However, its rugged construction, endurance, and high payload capacity, make it perfect for carrying out missions in the open seas for extended period of times, carrying in its torpedo shaped keel a full array of scientific equipment and acoustic sensors. Caravela was designed to be fully autonomous but capable of responding to commands issued from land or any sea platform via a remote RF/Satellite communication link. This link provides a data channel for receiving mission sensor data from the vehicle and for sending operator-generated commands to the vehicle to re-direct its mission if required. At the heart of the Caravela vessel is an integrated navigation, guidance, and control system that allows it to follow pre-determined paths with great accuracy. The vessel is both a testbed to try out advanced concepts in vehicle/mission control and radar-based obstacle avoidance and a demonstrator of technologies for the marine science community. The estimated range of operation of Caravela is 700 nautical miles. The propulsion system consists of two electrically driven propellers at the stern of the vehicle. The hull houses two Diesel generators that charge a pack of batteries. The main particulars of Caravela are the following. Length overall: 10m; beam of hull: 2m; draft of hull (without mast or keel): 2.3m; mast height: 3m; keel height: 2.5m; “torpedo” underwater: 4.5m length / 1.2m diameter.



Development of the Caravela was motivated by the need to reduce the cost of operations and improve the efficiency of oceanographic vessels at sea. Conventional oceanographic vessels require a large support crew, are costly to operate, and their availability is often restricted to short periods during the year. However, a large number of oceanographic missions consist of routine operations that could in principle be performed by robotic vessels capable of automatically acquiring and transmitting data to one or more support units installed on shore. In the future, the use of multiple autonomous oceanographic vessels will allow researchers to carry out synoptic studies of the ocean on time and space scales appropriate to the phenomena under study. Furthermore, these vessels will play a major role in enabling scientists to actually program and follow the execution of missions at sea from the safety and comfort of their laboratories.

### **3. Vehicle Control**

This section provides a brief summary of challenging problems in the area of marine vehicle control and guides the reader through some of the techniques used for solving them. The presentation is naturally biased towards the research work done at IST/ISR in the process of developing control algorithms for the vehicles described in the previous section. However, the types of problems addressed and the references cited are believed to be sufficiently broad and contain enough information to give the reader a balanced vision of the main trends in the field. See also (Fossen 2002) and the references therein for background material.

#### **3.1 Control problems: motivation**

There is considerable interest in the development of advanced methods for motion control of marine vehicles (including surface and underwater robots) in the presence of unknown ocean currents, wave action, and vehicle modelling uncertainty. Among the problems studied, the following categories are especially relevant and will be briefly described below:

- i) Vertical and horizontal plane control
- ii) Pose (position and attitude) control
- iii) Trajectory tracking and path following control
- iv) Cooperative motion control of multiple marine vehicles.

*Vertical and horizontal plane control* - in a vast number of mission scenarios, underwater vehicles are required to maneuver in the vertical and horizontal planes while tracking a desired speed profile bounded away from zero. Examples include heading control in the horizontal plane and depth or altitude control (above the seabed) in the vertical plane. See (Silvestre and Pascoal 1997a, Silvestre 2000, Fossen 2002, Silvestre and Pascoal 2004) and the references therein. More challenging applications require depth control close to the sea surface, in the presence of strong wave action (Silvestre and Pascoal, 1997b). This type of control is required for both streamlined and bluff bodies of which the Infante AUV and the Sirene AUV, respectively are representative examples. The first class of bodies have a preferred direction of motion and control is usually accomplished by resorting to simplified

dynamic models of motion obtained by linearizing their nonlinear dynamics about trimming conditions. The second class, however, do not have a preferred direction of motion. This makes the task of controlling them harder, for one must resort to more complex nonlinear dynamic models of motion. The problem of control in the horizontal plane is also relevant in the case of autonomous surface craft such as the Delfim or Caravela vessels.

*Pose Control* - a completely different class of problems arises when an underwater vehicle must be steered to a final target point with a desired orientation. This situation calls for the development of controllers to maneuver the vehicle at speeds around zero. The problem is especially challenging when the number of actuators of the vehicle is fewer than its degrees of freedom, as in the case of the Sirene AUV (Aguiar 2001). In this situation, theoretical limitations arising from the fact that the vehicles are non-holonomic (Brockett 1983) dictate that discontinuous, hybrid, or even time-varying feedback control laws be used. See (Aguiar 2001, Aguiar 2002a, 2002b, 2002c, 2002d) and the references therein for discussions on this subject.

*Trajectory Tracking and Path Following* – trajectory tracking refers to the problem of making a marine vehicle track a time-parameterized reference curve in two-dimensional or three-dimensional space (Silvestre 2000, 2002). Stated in simple terms, one requests that the vehicle be at assigned spatial coordinates at assigned instants of time. This requires that the velocity of the vehicle be controlled with respect an inertial frame. As is well known, this may lead, in the case of an AUV faced with strong currents, to a situation where the vehicle surfaces stall and control authority is drastically reduced. Furthermore, trajectory tracking control often leads to jerky motions of the vehicle (in its attempt to meet stringent spatial requirements) and to considerable actuator activity. These problems are somehow attenuated when the temporal constraints are lifted, which brings us to the problem of path following. By this we mean the problem of forcing a vehicle to converge to and follow a desired spatial path, without any temporal specifications (Samson 1992, Micaelli and Samson 1993, Silvestre 2000, Aicardi et al. 2001, Encarnação 2002, Fossen 2002, Encarnação and Pascoal 2000c). However, we will still require that the vehicle track a desired temporal speed profile. The latter objectives occur for example when an autonomous surface vessel must cover a certain area by performing a “lawn mowing” maneuver along desired tracks with great accuracy, at speeds determined by a scientific end-user. The underlying assumption in path following control is that the vehicle’s forward speed tracks the desired speed profile, while the controller acts on the vehicle’s orientation to drive it to the path. Typically, smoother convergence to the path is achieved when path following strategies are used instead of trajectory tracking control laws, and the control signals are less likely to be pushed to saturation. This interesting circle of ideas opens the door to more sophisticated strategies that naturally combine some of the attributes of trajectory tracking and path following, as first suggested in the pioneering work of (Hauser and Hindman, 1995) and recently pursued in (Encarnação and Pascoal 2001a, Fossen 2002, Skjetne et al. 2002b, 2004).

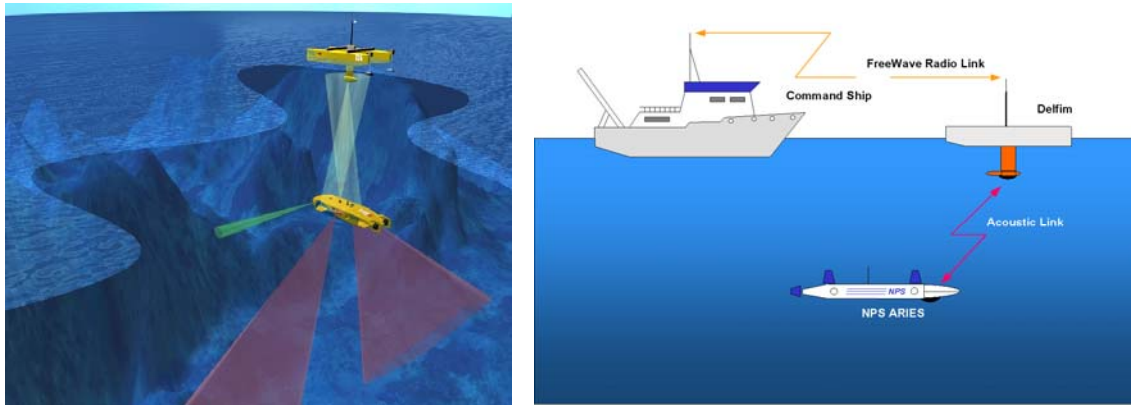

Figure 6. Coordinated motion control. Left: the Infante AUV and the Delfim ASC; Right: The ARIES AUV and the Delfim ASC - planning of the 2001 Azores mission (courtesy of Prof. Anthony Healey, NPS, Monterey, CA, USA).

*Cooperative motion control. Coordinated path following.*

In a great number of mission scenarios multiple autonomous marine vehicles must work in cooperation. The rationale for this problem can be best understood by referring to a number of practical examples:

i) *Combined autonomous surface craft / autonomous underwater vehicle control.* In this scenario an ASC must follow a desired path accurately and an AUV operating at a fixed depth must follow exactly the same horizontal path (shifted in the vertical), while tracking the ASC motion along the upper path. The AUV serves as a mobile sensor suite to acquire scientific data while the ASC plays the role of a fast communication relay between the AUV and a support ship. Thus, the ASC effectively explores the fact that high data rate underwater communications can best be achieved if the *emitter and the receiver are aligned along the same vertical line* in order to avoid multipath effects. Notice how both vehicles must follow exactly the same type of path, which is imposed by the scientific missions at hand. This operational scenario was first advanced in the scope of the Asimov project of the EU (Asimov Team 2000) and is depicted in Figure 6 (left), which illustrates coordinated operation of the Infante AUV and Delfim ASC. The same figure on the right shows also the type of experiments that were carried out at sea in the Azores, with the Aries AUV of the NPS, Monterey and the Delfim ASC communicating with each other using an acoustic modem.

ii) *Combined autonomous underwater vehicle control: image acquisition.* This scenario occurs when an underwater vehicle carries a strong light source and illuminates the scenery around a second underwater vehicle that must follow a pre-determined path and acquire images for scientific purposes.

iii) *Combined autonomous underwater vehicle control: fast acoustic coverage of the seabed.* In this important case, two vehicles are required to maneuver above the seabed at identical or different depths, along parallel paths, and map the sea bottom using two copies of the same suite of acoustic sensors (e.g. sidescan, mechanically scanned pencil beam, and sub-bottom profiler). By requesting the vehicles to traverse identical paths so as to make the acoustic beam coverage overlap on the seabed, large areas can be covered quickly. One can also envision a scenario where the vehicles use a set of vision sensors to inspect the same scenery from two different viewpoints to try and acquire three-dimensional images of the seabed.



In the above cases, one of the vehicles (leader) follows a path and the second vehicle (follower) is required to track the first one along a path that is related to that of the leader. A cursory analysis of the problem seems to indicate that a solution is at hand once a path following and a trajectory controller have been found for the leader and the follower vehicle, respectively. However, the problem is far more complex than a simple analysis suggests. Consider for example the first mission scenario, where the (leader) surface vehicle may exhibit relatively large path following errors due to wind, currents and wave action. It would be a bad strategy for the underwater vehicle to track the (possibly “jerky”) trajectory of the ASC closely. In fact, it is far better for the AUV (that is subject to far less external disturbances) to remain on its nominal spatial path and to maneuver along that path so as to “stay in the vicinity” of the leader. This will enable each vehicle to remain inside the projected area of the cone of communications of the other.

The problems described will henceforth be referred to as *coordinated path following*, a name that was chosen to stress the fact that the vehicles follow assigned paths but adjust their speeds to coordinate themselves in time as the mission unfolds. See (Fossen 2000, Encarnação and Pascoal 2001b, Encarnação 2002, Skjetne et al. 2002a, 2003, Lapiere et al. 2003b, Ghabcheloo et al. 2005b) and the references therein for an introduction to and an historical perspective of this vibrant topic of research. See also (Kyrkjebo and Pettersen 2003, Kyrkjebo et al. 2004) for a very interesting type of cooperative motion control problems with applications in ship rendez-vous maneuvers. Coordinated path following falls in the scope of the general problem of cooperative control, which has received considerable attention in the fields of air, space, and ground robotics (Desai et al. 1998, Beard et al. 1999, Giuletti 2000, Queiroz et al. 2000, Mesbahi et al. 2001, Pratchter et al. 2001, Ogren et al. 2002, Jadbabaie et al. 2003), and, to a less extent, in the field of marine robots (Stilwell and Bishop 2000, Bachmayer and N. Leonard 2002, Bhatta and Leonard 2002). The work reported in the literature addresses a large class of topics that include, among others, formation flying, coordination of groups of mobile autonomous agents, control of the “center of mass” and radius of dispersion of swarms of vehicles, and uniform coverage of an area by a group of ground robots, to name but a few. We chose to focus on coordinated path following because this topic is well rooted in solid practical applications and also because its mathematical formulation is closely related to that of path following, which is also covered in this chapter. At this point, it is important to stress that the type of problems tackled in the field of marine robotics are far more difficult than the corresponding ones in air or on land, because underwater navigation and communications are exceedingly difficult. Even at a theoretical level, these limitations pose formidable challenges to system designers because coordination must be achieved in the presence of time-dependent, low bandwidth communication links that are plagued with temporary failures.

### **3.2 Control problems: design techniques**

This section describes a number of control techniques that can be used to solve the control problems introduced above. Space limitations preclude us from presenting complete details of the mathematical machinery needed. Instead, we cite relevant

publications and present the key ideas involved. The presentation is naturally biased towards the research work done at IST/ISR.

For the sake of completeness we start by describing the general form of the equations of motion of marine vehicles, with a bias towards AUVs. The basic notation will however apply to all kinds of marine vehicles. See (Fossen 2000) and the references therein for a lucid presentation of this subject and for an extension to the modeling of surface craft. The interested reader will find complete dynamic models for the Sirene, Delfim, and Infante marine vehicles in (Aguiar 2002a), (Prado 2005), and (Silvestre 2000), respectively including details for their implementation in Matlab. The equations are developed using an inertial frame  $\{I\}$  and body-fixed frame  $\{B\}$  that moves with the vehicle. The following notation is required :

- $\mathbf{p} = [x, y, z]^T$  - position of the origin of  $\{B\}$  in  $\{I\}$ ;
- $\mathbf{v} = [u, v, w]^T$  - linear velocity of the origin of  $\{B\}$  in  $\{I\}$ , expressed in  $\{B\}$  ( $u, v, w$  denote surge, sway, and heave speed, respectively);
- $\boldsymbol{\lambda} = [\phi, \theta, \psi]^T$  - vector of Euler angles (roll, pitch, and yaw) that describes the orientation of frame  $\{B\}$  with respect to  $\{I\}$ ;
- $\boldsymbol{\omega} = [p, q, r]^T$  - angular velocity of  $\{B\}$  relative to  $\{I\}$ , expressed in  $\{B\}$ ;
- $R := {}^B_I R(\boldsymbol{\lambda})$  - rotation matrix from  $\{B\}$  to  $\{I\}$ , parameterized locally by  $\boldsymbol{\lambda}$ ;  $R$  is orthonormal and  $R = I$  for  $\boldsymbol{\lambda} = 0$ .
- $Q := Q(\boldsymbol{\lambda})$  - matrix that relates body-fixed angular velocity  $\boldsymbol{\omega}$  to Euler angles rates. Matrix  $Q$  satisfies  $d\boldsymbol{\lambda}/dt = Q\boldsymbol{\omega}$  and equals the identity for  $\boldsymbol{\lambda} = 0$ .

Let

$$\mathbf{x}_{dyn} = \begin{bmatrix} \mathbf{v} \\ \boldsymbol{\omega} \end{bmatrix}; \quad \mathbf{x}_{kin} = \begin{bmatrix} \mathbf{p} \\ \boldsymbol{\lambda} \end{bmatrix},$$

where  $\mathbf{x}_{dyn}$  and  $\mathbf{x}_{kin}$  denote the dynamic and kinematic variables, respectively that are used to describe the motion of the vehicle. Further let

$$L(\boldsymbol{\lambda}) = \begin{bmatrix} R(\boldsymbol{\lambda}) & 0 \\ 0 & Q(\boldsymbol{\lambda}) \end{bmatrix}.$$

Using the above notation, the vehicle dynamics and kinematics can be described by (Silvestre 2000, Silvestre et al. 2002)

$$M_{RB} \frac{d}{dt} \mathbf{x}_{dyn} + C_{RB}(\mathbf{x}_{dyn}) \mathbf{x}_{dyn} = \boldsymbol{\tau} \left( \frac{d}{dt} \mathbf{x}_{dyn}, \mathbf{x}_{dyn}, \boldsymbol{\lambda}, \boldsymbol{\delta}, \mathbf{n} \right)$$

$$\frac{d}{dt} \mathbf{x}_{kin} = L(\boldsymbol{\lambda}) \mathbf{x}_{dyn}$$

where  $M_{RB}$  and  $C_{RB}$  denote the rigid body inertia matrix and the matrix of Coriolis and centripetal terms respectively, and  $\boldsymbol{\tau}$  is the vector of external forces and torques applied to the rigid body. Vector  $\boldsymbol{\tau}$  can be further decomposed as

$$\begin{aligned} \boldsymbol{\tau} := & \boldsymbol{\tau}\left(\frac{d}{dt}\mathbf{x}_{dyn}, \mathbf{x}_{dyn}, \boldsymbol{\lambda}, \boldsymbol{\delta}, \mathbf{n}\right) = \boldsymbol{\tau}_{rest}(\boldsymbol{\lambda}) + \boldsymbol{\tau}_{add}\left(\frac{d}{dt}\mathbf{x}_{dyn}, \mathbf{x}_{dyn}\right) + \\ & \boldsymbol{\tau}_{surf}(\mathbf{x}_{dyn}, \boldsymbol{\delta}) + \boldsymbol{\tau}_{visc}(\mathbf{x}_{dyn}, \boldsymbol{\delta}) + \boldsymbol{\tau}_{prop}(\mathbf{x}_{dyn}, \mathbf{n}) \end{aligned}$$

where  $\boldsymbol{\tau}_{rest}$  is the vector of (restoring) forces and moments caused by the interplay between gravity and buoyancy and  $\boldsymbol{\tau}_{add}$  captures the so-called added mass terms. Vector  $\boldsymbol{\tau}_{surf}$  contains the forces and moments generated by the deflecting surfaces,  $\boldsymbol{\tau}_{visc}$  consists of the hydrodynamic forces and moments exerted on the vehicle's body (including damping terms), and  $\boldsymbol{\tau}_{prop}$  is the vector of forces and moments generated by the propellers. In the case of the Infante AUV, the input vector  $\boldsymbol{\delta} = [\delta_b, \delta_s, \delta_r]^T$  consists of:  $\delta_b$  – common bow plane deflection,  $\delta_s$  – common stern plane deflection, and  $\delta_r$  – common rudder deflection. Vector  $\mathbf{n}$  contains the speeds of rotation of the two stern propellers. It is now routine to rewrite the above equations in standard state-space form as (Silvestre and Pascoal 2002)

$$\mathcal{P} := \begin{cases} \frac{d}{dt}\mathbf{x}_{dyn} = \mathcal{F}_{dyn}(\mathbf{x}_{dyn}, \mathbf{x}_{kin}) + \mathcal{B}(\mathbf{x}_{dyn}) + \mathcal{H}(\mathbf{x}_{dyn})\mathbf{u} \\ \frac{d}{dt}\mathbf{x}_{kin} = \mathcal{F}_{kin}(\mathbf{x}_{dyn}, \mathbf{x}_{kin}) = L(\boldsymbol{\lambda})\mathbf{x}_{dyn} \end{cases} \quad (1)$$

by making  $\mathbf{u} = [\delta^T, n^T]^T$ . The total speed of the vehicle will be denoted  $v_t = \|\mathbf{v}\|_2$ . At this point we also recall the classical definitions of angle of attack  $\alpha = \sin^{-1}(w/(u^2 + w^2)^{1/2})$ , sideslip angle  $\beta = \sin^{-1}(v/v_t)$ , and flight path angle (angle that the total velocity vector makes with the horizontal and equals  $\gamma = \theta - \alpha$  when vehicle motion is restricted to the vertical plane).

### 3.2.1 Vertical and horizontal plane control

There are a number of techniques available for the control of AUVs in the vertical and horizontal planes. See for example the seminal work of (Healey and Lienard 1993) and the techniques described in (Fossen 2002) for an introduction to control design using linear state-space feedback, sliding mode control theory, and adaptive control. For our purposes, we assume that the general AUV model presented above can be divided into two sub-models for the vertical and horizontal planes. This procedure is fully justified for the case where the vehicle executes maneuvers that require light interaction between steering in the horizontal plane and diving in the vertical plane. We further assume that the vehicle under consideration has a preferred direction of motion that corresponds to the situation where the vehicle is levelled and “flies straight” at a constant speed  $v_t > 0$ . Mathematically, this corresponds to an equilibrium or trimming condition at which the dynamic state  $\mathbf{x}_{dyn}$  is defined by  $u = v_t$ ,  $v = w = p = q = r = 0$ , the roll and pitch angles are set to zero, and the input vector  $\mathbf{u}$  is defined accordingly. Assuming the vehicle motion does not deviate too much from this equilibrium condition, simple dynamic models can be obtained by linearizing the nonlinear dynamics about trimming. Naturally, the simplified models can be parameterized by the total speed  $v_t$ . This motivates the approach taken at IST/ISR towards the development of AUV control laws that are well rooted in gain-scheduling control theory (Silvestre and Pascoal 1997a, Silvestre

2000, Silvestre and Pascoal 2004, 2005). With the set-up adopted, the design of a controller to achieve stabilization and adequate performance of a given nonlinear plant (system to be controlled) involves the following steps (Khalil 2000, Rugh *et al.* 2000):

- i) *Linearizing* the plant about a finite number of representative trimming conditions (also called equilibrium or trimming points),
- ii) Designing *linear controllers* for the plant linearizations at each trimming point,
- iii) *Interpolating* the parameters of the linear controllers of Step ii) to achieve adequate performance of the linearized closed-loop systems at all points where the plant is expected to operate; the interpolation is performed according to the vehicle's forward speed, and the resulting family of linear controllers is referred to as a *gain scheduled controller*,
- iv) *Implementing* the gain scheduled controller on the original nonlinear plant.

The strategy described effectively reduces the problem of nonlinear control system design to that of designing a finite number of linear controllers, as described in step ii). This allows the system designer to use techniques that explicitly address the issues of robust stability and performance in the presence of plant uncertainty (Athans *et al.* 2005). In our work, the methodology selected for linear control system design relies on the reduction of an  $H_\infty$  (H-infinity) performance criterion (Doyle *et al.* 1989). The starting point in this design technique is the standard linear feedback system of Figure 7 (left) where  $\mathbf{w}$  is the input vector of exogenous signals (commands, disturbances, and sensor noise),  $\mathbf{z}$  is an output vector that includes the signals (tracking errors, actuation signals, etc.) to be reduced,  $\mathbf{y}$  is the vector of measurements that are available for feedback, and  $\mathbf{u}$  is the vector of actuator signals (inputs to the plant).

The generalized plant  $\mathcal{G}$  consists of the linearized model of the plant together with appended dynamic weights that shape the exogenous and internal signals in the frequency domain (Figure 7, right). For example, in the design of a depth controller using stated feedback, detailed in (Silvestre and Pascoal, 1997a),  $\mathbf{w}_1$  is the depth command  $z_{cmd}$  that must be tracked. Vector  $\mathbf{w}_2$  includes the input noise to each of the

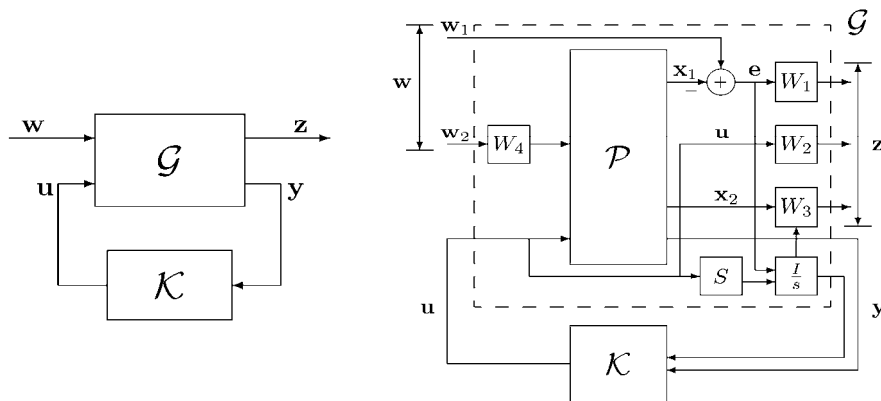

Figure 7. Control design. Left: plant/controller in a feedback configuration; Right: design model with appended weights

sensors that provide measurements of the state variables, as well as disturbance inputs to the states  $w$  and  $q$  of the plant. Vector  $\mathbf{u}$  consists of the actuation signals for the bow and stern planes deflections, and  $\mathbf{x}_1$  is the depth variable  $z$ . Vector  $\mathbf{x}_2$  includes the variables  $\alpha, q, \theta$  that are also penalized in the design process. Notice the existence of a block of integrators  $I/s$  that operates on the tracking error  $e$  and on the entries of the control input vector  $\mathbf{u}$  that are selected by the matrix  $S$ . Integral action on the error is required to ensure zero steady state in response to step commands in  $\mathbf{w}_1$ . Integral action on the entries of  $\mathbf{u}$  introduces a “washout” on the particular control inputs selected. In the present case, the “washout” ensures zero bow plane deflection at trimming conditions. With the above choices,  $\mathbf{y} = [\alpha, q, \theta, z, (z_{cm} - z)/s, \delta_b/s]^T$ . The dynamic or scalar weights  $W_1$  through  $W_4$  are introduced to achieve command and input-output requirements.

Suppose the feedback system is well-posed, and let  $T_{zw}$  denote the closed loop transfer matrix from  $\mathbf{w}$  to  $\mathbf{z}$ . The  $H_\infty$  control problem can now be briefly described as follows: given a number  $\gamma > 0$  find, if possible, a controller  $\mathcal{K}$  that yields closed-loop stability and makes the infinity norm  $\|T_{zw}\|_\infty$  (that is, maximum input-output “energy amplification” of  $T_{zw}$ ) smaller than  $\gamma$ . The positive number  $\gamma$  and the weights appended in  $\mathcal{G}$  play the role of tuning knobs to try and meet adequate closed-loop performance specifications in the frequency domain.

To solve this problem, one can resort to Linear Matrix Inequalities – LMIs (Boyd et al., 1994) which are steadily becoming the tool par excellence for advanced control system design. In fact, many control problems can be cast as LMI problems that can be solved efficiently using convex programming techniques. The case of AUV control using state feedback is studied in (Silvestre and Pascoal, 1997a). The far more complex and realistic cases of static output feedback and reduced order static output feedback are reported in (Silvestre and Pascoal, 2004) and (Silvestre and Pascoal, 2005), respectively. These references include also details on how to solve the practical problem of gain scheduled controller implementation mentioned in step iv) by using a dedicated velocity algorithm that is also referred to as the “ $\delta$ - implementation” (Kaminer et al., 1995). Using this implementation, the trimming values for the plant inputs and for the state variables that are not explicitly required to track kinematic reference inputs are automatically “learned” during operation and do not need to be computed off-line. Figure 8 shows the type of performance obtained with a static output feedback controller during tests with the Infante AUV at sea.

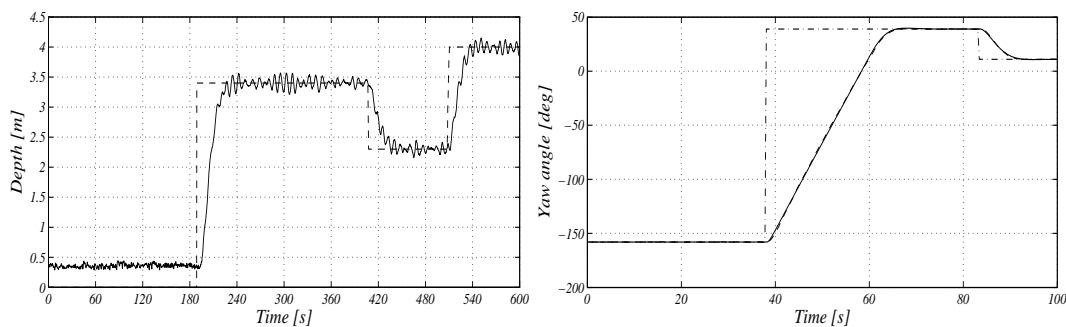

Figure 8. Depth and Heading Control of the Infante AUV.



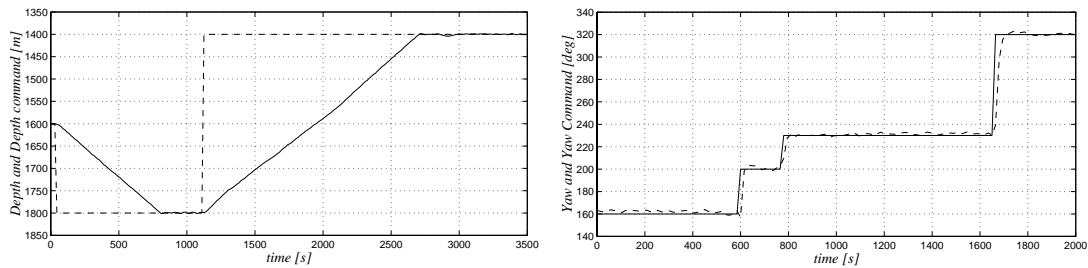

Figure 9. Depth and Heading Control of the Sirene AUV.

### 3.2.2 Pose control

The problem of pose control is clearly of a different breed and will only be briefly touched upon in this section. The vehicles involved are usually bluff bodies that must maneuver at low speed during their final approach to a target position. As discussed before, the problem is especially hard to solve when the vehicles are underactuated because there is no smooth (or even continuous), time-invariant state-feedback control law that will yield asymptotic stability of the desired pose (position and orientation) (Brockett, 1983).

At IST/ISR, work on this subject was highly motivated by the participation in the Desibel project (Brisset et al. 1995). Work evolved at both a theoretical and “practical level”. From a theoretical standpoint, two methodologies were developed for pose control of the Sirene AUV. The first method sought inspiration from previous related work in the field of wheeled robots (Aicardi et al. 1995) where the kinematics of a robot are re-written in polar coordinates, thereby introducing a discontinuity in the control law as a form of obviating some of the limitations imposed by Brockett’s result. See (Aguiar et al. 2001; Aguiar 2002a) and the references therein. The second method used a totally different approach that borrowed from logic-based hybrid control theory (Aguiar and Pascoal 2002d). The transition from theory to practice, done in the scope of the Desibel project, witnessed the development of a set of control laws for vehicle maneuvering that were tested off the coast of Toulon, France down to depths of 2000 m (Aguiar and Pascoal, 1997, Oliveira et al. 1998c). Figure 9 shows practical results of heading and depth control of the vehicle.

### 3.2.3 Trajectory tracking and path following control

This section offers a short summary of some design techniques that can be used for trajectory tracking and path following of marine vehicles. Once again, we skip the mathematical details. However, we guide the reader to the appropriate references.

#### *Trajectory tracking*

In a number of aeronautical applications, trajectory tracking controllers for autonomous vehicles have traditionally been designed using the following methodology. First, an inner loop is designed to stabilize the vehicle dynamics. Then, using time-scale separation criteria, an outer loop is designed that relies essentially

on the vehicle's kinematic model and converts trajectory tracking errors into inner loop commands. In classical missile control literature this outer loop is usually referred to as a guidance loop. Following this classical approach, the inner control loop is designed based on vehicle dynamics, whereas the outer guidance law is essentially based on kinematic relationships only. During the design phase, a common rule of thumb is adopted whereby the inner control system is designed with sufficiently large bandwidth to track the commands that are expected from the guidance system (the so called time-scale separation principle). However, since the two systems are effectively coupled, stability and adequate performance of the combined systems are not guaranteed. This potential problem is particularly serious in the case of marine vehicles, which lack the agility of fast aircraft and thus impose tight restrictions on the closed loop bandwidths that can be achieved with any dynamic control law. Motivated by the above considerations, a new methodology was introduced in (Silvestre, 2000; Silvestre et al., 2002) for the design of guidance and control systems for marine vehicles whereby the guidance and control are designed simultaneously. Before we proceed, we introduce the following notation and concepts. See (Silvestre et al., 2002) for a rigorous exposition.

We start by noticing that the kinematic variables  $\mathbf{x}_{kin}$  in (1) can be split as

$$\mathbf{x}_{kin} = \begin{bmatrix} \mathbf{x}_{kin,i}^T, \mathbf{x}_{kin,o}^T \end{bmatrix}^T$$

where  $\mathbf{x}_{kin,i}$  denotes the kinematic variables that appear explicitly in the top equations of (1) and  $\mathbf{x}_{kin,o}$  are the remaining variables (the yaw variable and the position vector  $\mathbf{p}$  do not appear explicitly in the dynamic equations). A *generalized trimming trajectory*  $Y_C^g$  for the set of equations (1) can be defined as

$$Y_C^g := \left\{ (\mathbf{x}_{dyn_C}, \mathbf{x}_{kin_c}(\cdot), \mathbf{u}_C) : \begin{bmatrix} \mathcal{F}_{dyn}(\mathbf{x}_{dyn_C}, \mathbf{x}_{kin,i_C}) + \mathcal{B}(\mathbf{x}_{dyn_C}) + \mathcal{H}(\mathbf{x}_{dyn_C})\mathbf{u}_C = 0 \\ \mathcal{F}_{kin,i}(\mathbf{x}_{dyn_C}, \mathbf{x}_{kin,i_C}) = 0 \end{bmatrix} \right\}$$

where it is assumed that the kinematic equations for  $\mathbf{x}_{kin,o}$  do not depend on  $\mathbf{x}_{kin,i}$ . Stated in simple terms, a generalized trimming trajectory is obtained by freezing the input  $\mathbf{u}$  at some value  $\mathbf{u}_C$ . A *trimming trajectory* of (1), denoted  $Y_c$ , is now simply obtained from  $Y_C^g$  by extracting the kinematic components  $\mathbf{x}_{kin_c}$ , that is, a trimming trajectory is determined by the evolution of the linear position and orientation of the vehicle when the input vector is frozen. Often, by a trimming trajectory we also mean the evolution of the position coordinates only. The meaning will be clear from the context. Associated with (1) we can of course consider other (not necessarily trimming) trajectories that are obtained by letting the input vector evolve according to an arbitrary time profile. In this setting, the problem of trajectory tracking can be defined as that of making the state space of a vehicle tend asymptotically to a desired generalized trajectory, by proper choice of the input  $\mathbf{u}$ . To do this, an adequate generalized tracking error vector must be defined. Instead of considering the general case, we now focus on the case of trimming trajectories. A possible choice for the error space is given through the nonlinear transformation

$$NLT := \begin{cases} \mathbf{v}_E = \mathbf{v} - \mathbf{v}_C \\ \boldsymbol{\omega}_E = \boldsymbol{\omega} - \boldsymbol{\omega}_C \\ \mathbf{p}_E = R^{-1}(\mathbf{p} - \mathbf{p}_C) \\ \boldsymbol{\lambda}_E = \arg(R_E) \end{cases}$$

where  $R$  is the rotation matrix from body to inertial frame,  $R_E$  denotes the rotation matrix from vehicle body-axis to the “desired” target orientation along the trajectory, and  $\arg(\cdot)$  is the operator that extracts the arguments (Euler angles) of  $R_E$ .

The new design method proposed builds on the following results: i) the trimming trajectories of autonomous vehicles correspond to helices parameterized by the vehicle’s linear speed, yaw rate, and flight path angle (in the case of ocean surface vehicles, the trimming parameters are simply linear speed and yaw rate), ii) tracking of a trimming trajectory by a vehicle is equivalent to driving a conveniently defined generalized tracking error (NLT above) to zero, and iii) the linearization of the generalized error dynamics about any trimming trajectory is time invariant (this fact is not obvious).

Based on the above results, the problem of integrated design of guidance and control systems for accurate tracking of trajectories that consist of the juxtaposition of trimming trajectories can be cast in the framework of gain-scheduled control theory. In this context, the vehicle’s linear speed, yaw rate, and flight path angle play the role of scheduling variables that interpolate the parameters of linear controllers designed for a finite number of representative trimming trajectories. This leads to a new class of trajectory tracking controllers that exhibit two major advantages over classical ones: i) stability of the combined guidance and control system is guaranteed, and ii) zero steady state error is achieved about any trimming trajectory. As in the previous section, controller scheduling and implementation is done by using a generalization of the  $\delta$ -implementation strategy derived in (Kaminer et al., 1995), see the details in (Silvestre, 2000). Interestingly enough, with this strategy the structure of the final tracking control law is such that the trimming values for the plant inputs and for the states variables that are not explicitly required to track kinematic reference inputs are automatically “learned” during operation. The importance of this property can hardly be overemphasized, for it is in striking contrast with most known methods for trajectory tracking which build on the unrealistic assumption that all input and state variables along the trajectory to be followed are computed in advance.

### *Path Following*

As explained before, path following is the problem of making a vehicle converge to and follow a desired spatial path, denoted  $\Gamma$ , while tracking a desired speed profile. The temporal and spatial goals are therefore separated. Often, it is simply required that the speed of the vehicle remain constant. In what follows, it is generally assumed that the path is parameterized in terms of its length. A point on the path is therefore specified in terms of its curvilinear abscissa, denoted  $s \geq 0$ . However, the path can

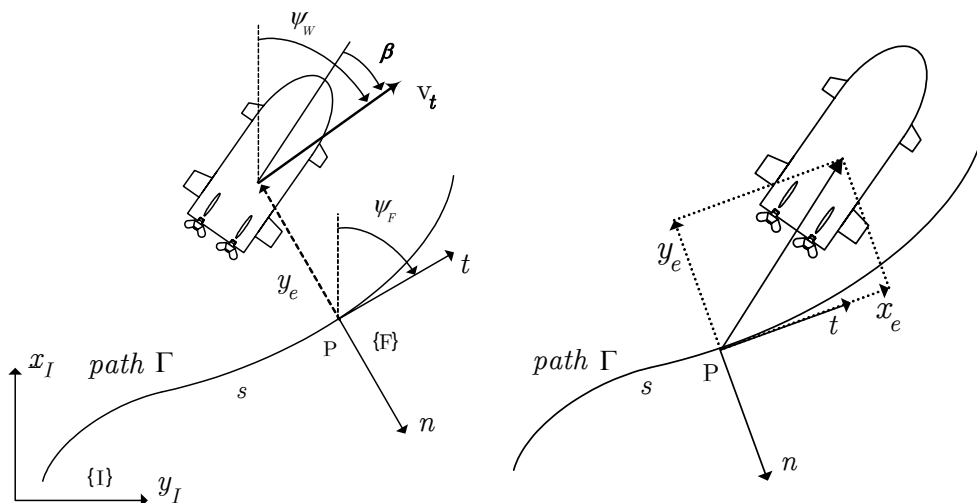

Figure 10. Path Following. Left: closest point strategy.  
Right: an extra degree of freedom (virtual target strategy)

also be parameterized in terms of any other convenient parameter  $\zeta$  given by  $\zeta = g(s); g(0) = 0$ , where  $g(\cdot)$  is an invertible function.

The solutions to the problem of path following described below are rooted in the work described in (Samson 1992, Micaelli and Samson 1993) for wheeled robots. When extended to marine robots, the key ideas explored can be briefly explained by considering Figure 10 (left), which depicts the situation where a vehicle follows a two dimensional path denoted  $\Gamma$ . A path following controller should compute i) the distance  $y_e$  between the vehicle's center of mass and the closest point  $P$  on the path (if this distance is well defined) and ii) the angle between the vehicle's total velocity vector  $v_t$  and the tangent  $t$  to the path at  $P$ , and reduce both to zero (Encarnação and Pascoal, 2000a). Stated equivalently, the objective is to align the total velocity vector with  $t$ . At this point, it is important to recall the definition of flow frame  $\{W\}$  of a vehicle:  $\{W\}$  is obtained from the body frame by rotating it through the angle  $\psi + \beta$ , thus leaving the x-axis of the flow frame aligned with the total velocity vector  $v_t$ . Recall also the definition of the Serret-Frenet  $\{F\} = (t, n)$  along a path, consisting of the tangent and normal to that path. Clearly,  $\{F\}$  plays the role of the flow frame  $\{W_v\}$  of a "virtual target vehicle" that should be tracked by the flow frame  $\{W\}$  of the actual vehicle. The mismatch between the two frames (as measured by linear distance  $y_e$  and angle  $\psi_e = \psi + \beta - \psi_F$  plays a key role in the definition of the error space where the path following control problem can be formulated and solved). These concepts can of course be generalized to the three-dimensional case (Encarnação and Pascoal 2000c, Encarnação 2002). Notice that in the case of a wheeled robot the current frame is simply replaced by its body frame because the robot does not exhibit sideslip; consequently, the total velocity vector is aligned with the  $x$ -body-axis.

At this point, different solutions to the problem of path following can be proposed. A solution that relies on gain-scheduling control theory and on the linearization of a

generalized error vector about trimming paths, akin to that previously described for trajectory tracking, is reported in (Silvestre 2000). See also (Kaminer et al. 1998, Hallberg et al. 1999) for an application of the same techniques to aircraft control. Formally, to define a trimming path we let  $Y_c = \mathbf{x}_{kin_c}(\cdot)$  be a trimming trajectory of a vehicle and let  $s(t) = \|\mathbf{v}_c\|t; \|\mathbf{v}_c\| \neq 0, t \geq 0$  where  $\|\mathbf{v}_c\|$  denotes the trimming speed. Given an arbitrary invertible function  $\zeta = g(s); s \geq 0, g(0) = 0$ , then

$$\Gamma_C = \Gamma_C(\zeta) := \left\{ \Pi_{\mathbf{p}} \mathbf{x}_{kin_c} \left( \frac{g^{-1}(\zeta)}{\|\mathbf{v}_c\|} \right); \zeta \geq 0 \right\},$$

where  $\Pi_{\mathbf{p}} \mathbf{x}_{kin_c}$  is the projection of  $\mathbf{x}_{kin_c}$  onto its first three components  $\mathbf{p}_C$ , is a *trimming path of the vehicle* parameterized by  $\zeta$ . It is now possible to define a generalized path following error (about a trimming path) that includes  $y_e$  and  $\psi_e$  referred to above in the two-dimensional case and to compute the time-invariant linearization of the generalized error dynamics. The procedure to develop a gain-scheduled path following controller follows now closely the procedure adopted for trajectory tracking system design. This methodology is at the core of the path following controllers that were successfully implemented and run on the Delfim ASC and the Bluebird aircraft, property of the Naval Postgraduate School, Monterey, California, USA (Kaminer et al. 1998, Hallberg et al. 1999). Figure 11 shows the results obtained with the Delfim ASC doing a lawn mowing maneuver over a seamount, off the coast of Terceira Island, in the Azores. In this mission, the ASC ran a path following algorithm along the longer transects, in the presence of a strong ocean current.

With the approach described *stability and performance properties can only be guaranteed locally*. To obtain global stability results, nonlinear control design methods must be brought to the fore. This was the approach taken in (Samson 1992) where an elegant and fruitful technique for path following was first proposed for wheeled robots. The new methodology is applicable to a very general set of paths, builds on solid results in nonlinear control theory, and allows for the design of stabilizing feedback controllers by resorting to Lyapunov-like arguments. However, controller design was based on the vehicle kinematics only. This is clearly insufficient for marine robots, because their equations of motion exhibit dynamic terms with parameter uncertainty that must be taken into account directly in the control

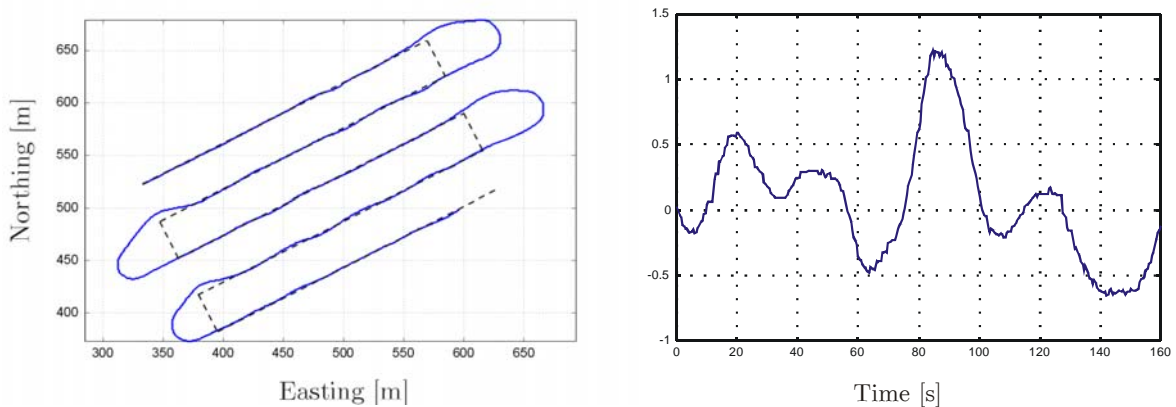

Figure 11. Path following at sea (Delfim ASC) in the presence of ocean currents, waves, and wind. Left- Lawn mowing maneuver; Right – deviation from the path (in meters).



design process. Furthermore, the motion of marine craft may be subjected to the influence of wind, ocean currents, and wave action, which poses additional challenges to control system design.

Motivated by these considerations, the work in (Encarnação 2000b, 2000c, 2002) and later refined in (Lapierre et al. 2003a), generalized the results derived for wheeled robots to ocean surface and underwater vehicles by deriving control laws to steer marine robots along desired paths. The key ideas behind the development of the nonlinear algorithms proposed can be simply explained for the two dimensional case as follows (see also the discussion at the beginning of this section). Assume without loss of generality that the total speed of the vehicle is held constant and compute the evolution of the path following error vector consisting of variables  $y_e$  and  $\psi_e$ , as functions of yaw rate  $r$ . Define a candidate Lyapunov function that is quadratic in the error variables, and use it to find a “kinematic”, nonlinear, feedback control law for  $r$  (as if it were a true input) to reduce the error vector to zero. Finally, go from the virtual control law for  $r$  to the actual physical input of the vehicle (torque  $N$ ) using backstepping techniques (Krstic et al. 1995). This procedure was extended to the three dimensional case and also to deal explicitly with unknown sea currents in (Encarnação and Pascoal 2000b) and (Encarnação et al. 2000c), respectively. The latter result requires that a nonlinear controller and a current observer be put together. Proving that the ensemble works correctly and biases the heading of the vehicle to counteract the current is not trivial, because of the lack of a separation principle for nonlinear systems.

At this point it is important to remark that the results obtained above inherit the limitation that is present in the path following control strategy for wheeled robots described for example in (Micaelli and Samson 1993): to prove convergence of the error vector, the initial position of the vehicle is restricted to lie inside a tube around the path, the radius of which must be smaller than the smallest radius of curvature that is present in that path. This restriction was entirely removed in (Lapierre et al. 2003a) by controlling explicitly the rate of progression of the virtual target to be tracked along the path, thus bypassing the problems that arise when the position of that target is simply defined by the projection of the actual vehicle on that path (Figure 11, right). See also (Soetanto 2003) where a similar technique was first proposed for wheeled robots and (Kaminer et al. 2005) for an extension of the same technique to deal with the problem of nonlinear path following for marine vehicles in the presence of parameter uncertainty. The design methodology proposed effectively creates an extra degree of freedom that can then be exploited to avoid the *singularities* that occur when the distance to path is not well defined (this occurs for example when the vehicle is located exactly at the center of curvature of a circular path). Interestingly enough, related strategies were explored in the work of (Skjetne et al. 2002b, 2004) on output maneuvering and also in the work of (del Rio et al. 2002).

### 3.2.4 Coordinated motion control

For reasons that have been explained before, we restrict ourselves to the problem of coordinated path following. An in-depth exposition of this challenging topic of

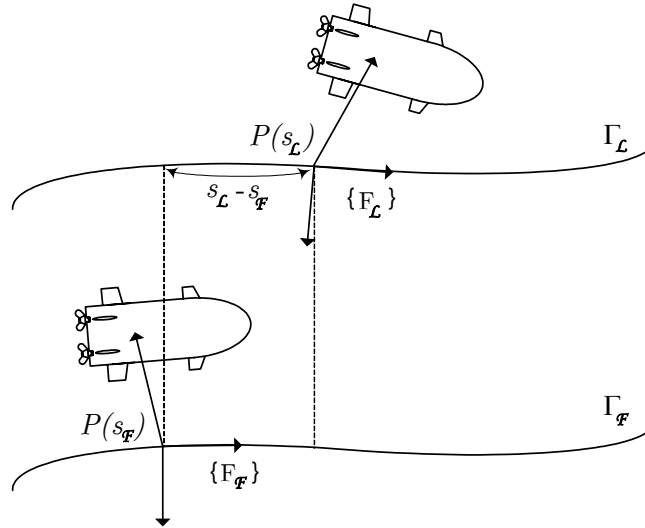

Figure 12. Coordinated path following (parallel paths)

research is outside the scope of this chapter. Instead, we give a fast paced presentation of the subject by keeping the mathematical formalism to a minimum. The key ideas explored in the sequence are easy to grasp and can be explained by referring to Figure 12, which depicts a *leader* AUV  $\mathcal{L}$  and a *follower* AUV  $\mathcal{F}$  and two parallel paths  $\Gamma_L$  and  $\Gamma_F$  parameterized by their “along-path” curvilinear abscissas  $s_L$  and  $s_F$ , respectively. Path  $\Gamma_F$  is obtained from  $\Gamma_L$  by shifting it down, vertically. The problem of coordinated path following can now be posed: given paths  $\Gamma_L$  and  $\Gamma_F$  a desired total speed profile  $v_t^d$  for vehicle L, derive control laws for vehicles L and F so that they: i) converge to their respective paths while tracking the desired speed profile (*spatial assignment*), and ii) synchronize their motions along the paths so that the line connecting their centers of mass remains vertical (*temporal assignment*). Using the terminology of coordinated motion control, we require that the two vehicles reach an “in-line” *formation pattern* while maneuvering along the paths. Another underlying requirement is that the *amount of information exchanged between the two vehicles should be kept to a minimum*. Ideally, only position information should be exchanged.

A solution to this problem was advanced in (Lapierre 2003b) by resorting to a technique that “almost-decouples” the spatial and temporal assignments referred to above: both the leader and follower execute path following algorithms, the leader traveling along its path at the desired speed profile. It is the task of the follower to adjust its total speed based on the measurement of a generalized “along-path distance” between the two vehicles. In the simple case illustrated in Figure 12, this distance is denoted  $s_{L,F}$  and is simply the difference between the along-path coordinates  $s_F$  and  $s_L$  of  $P_L$  and  $P_F$ , respectively. Intuitively, the follower speeds up or slows down in reaction to the distance between the “virtual target vehicles” involved in the path following algorithms. This strategy drastically reduces the amount of information that must be exchanged between the two vehicles. Controller design builds on Lyapunov theory and backstepping techniques. The resulting nonlinear feedback control law yields convergence of the two vehicles to the

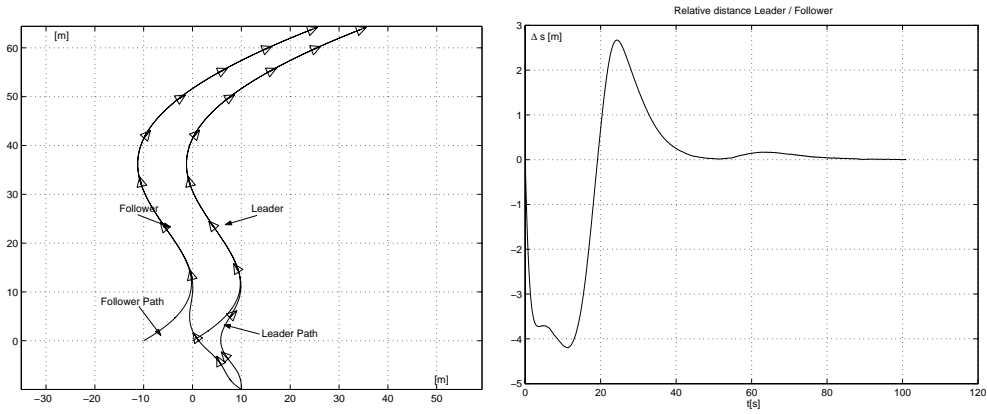

Figure 13. Coordinated path following. Left: Paths. Right: along-path distance between Leader and Follower.

respective paths and forces the follower to accurately track the leader asymptotically. Thus, the mathematical machinery supports the intuition behind the spatial/temporal almost decoupling assumption. Figure 13 shows the results of simulations with two underwater vehicles. See (Lapierre 2003b) for details. The right part of the figure shows clearly how the along-path distance between the two vehicles tends asymptotically to zero.

It is interesting to remark that the rationale for this strategy is already implicit in the work of (Encarnação and Pascoal 2001b) for coordinated path following of an ASC and an AUV. However, the strategy adopted is not easily generalized to more than two vehicles and requires that a large amount of information be exchanged between them. The solution described in (Lapierre 2003b) overcomes the latter constraint for the case of two vehicles. To overcome the first constraint, a different strategy must be adopted. This brings us to the body of the work initiated in (Ghabcheloo et al. 2004a, 2005a) for wheeled robots and extended in (Ghabcheloo et al. 2005b) for fully actuated underwater vehicles. The main results obtained show how to design coordinated path following controllers for multiple vehicles, arbitrary paths (not necessarily obtained through parallel displacements of a template path), and very general coordination patterns that are compatible with the paths to be followed.

Dealing with general paths and formation patterns is done by re-parameterizing the paths in terms of variables, say  $\zeta_i : i = 1, 2, \dots, N$  (where  $N$  is the number of vehicles) that are not necessarily their curvilinear abicssae  $s_i$ . For example, suppose one wishes to make  $N$  marine vehicles coordinate their motions along  $N$  concentric circumferences with radii  $R_i : i = 1, 2, \dots, N$  so that their centers of mass are aligned radially. Further assume we parameterize the circumferences in terms of parameters  $\zeta_i = s_i / (2\pi R_i)$  (this is equivalent to normalizing the total lengths of the circumferences to unity). Clearly, the vehicles are aligned as desired when  $\zeta_1 = \zeta_2 = \dots = \zeta_N$ . Having thus solved the problem of defining when coordination is achieved, one is now left with that of coordinating multiple vehicles in the presence of communication constraints. In particular, one wishes to specify the structure of the communication network. Namely, the communications lattice (what vehicle talks to what vehicle) and the type of information that is transmitted among the vehicles

(ideally, only the positions along their paths should be transmitted). The pioneering work in (Fax and Murray 2002a, b, Olfati and Murray 2003) showed how these issues can be addressed in the scope of graph theory (Biggs 1993). Possible assumptions are: i) the communications are bidirectional, that is, if vehicle  $i$  sends information to  $j$ , then  $j$  also sends information to  $i$ , and ii) the communications graph is connected (a communication graph is said to be connected if two arbitrary vertices, representing vehicles, can be joined by a communication path of arbitrary length). Notice that if assumption (ii) is not verified, then there are two or more clusters of vehicles and no information is exchanged among the clusters. Under these assumptions, using again an almost decoupling type of approach, it is possible to show that there exists a decentralized control law that will drive the vehicles to their paths and achieve coordination. See (Ghabcheloo et al. 2004a, 2004b, 2004c, 2005a, 2005b) for background material and for proofs of this and other related results. The tools used rely heavily on Lyapunov stability theory (Rouche et al. 1993).

The methodologies required to deal with the general problem of coordinated motion control of marine robots (of which that of coordinated path following is an important example) are still at their infancy. Challenging issues that warrant further research include the study of guaranteed stability and performance of coordinated path following systems when the communications network changes in time and/or fails temporarily. See for example (Mureau, 2005) and the references therein for a discussion of topics that may have some bearing on these issues.

#### **4. Mission Control and Operations at Sea**

The previous section described some of the techniques used for single and multiple marine vehicle control. In what follows we describe briefly how to transition from theory to practice. To do this, two key ingredients are needed: i) a distributed computer architecture, and ii) a software architecture for system implementation and human-machine interfacing. When implemented in a fully operational vehicle (equipped with the systems for navigation, guidance, and control, together with the remaining enabling systems for energy and scientific payload management, actuator control, and communications), the latter is often referred to as a Mission Control System. The literature on Mission Control is vast and lacks a unified treatment. In fact, the development of a Mission Control System for single or multiple vehicles reflects the background of the developing team, the applications envisioned, and the hardware available for Mission Control System implementation. Space limitations prevent us from giving an overview of the main trends in the important area of Mission Control. The interested reader is referred to (Healey et al. 1996a, Healey et al. 1996b, Oliveira et al. 1996, Pascoal et al. 1997, Oliveira et al. 1998a, Oliveira, 2003) and the references therein for some background material and an historical perspective.

##### **4.1 The CORAL Mission Control System**

For our purposes, a Mission Control System is simply viewed as a tool allowing a scientific end-user not necessarily familiarized with the details of marine robotics to program, execute, and follow the progress of single or multiple vehicles at sea. With

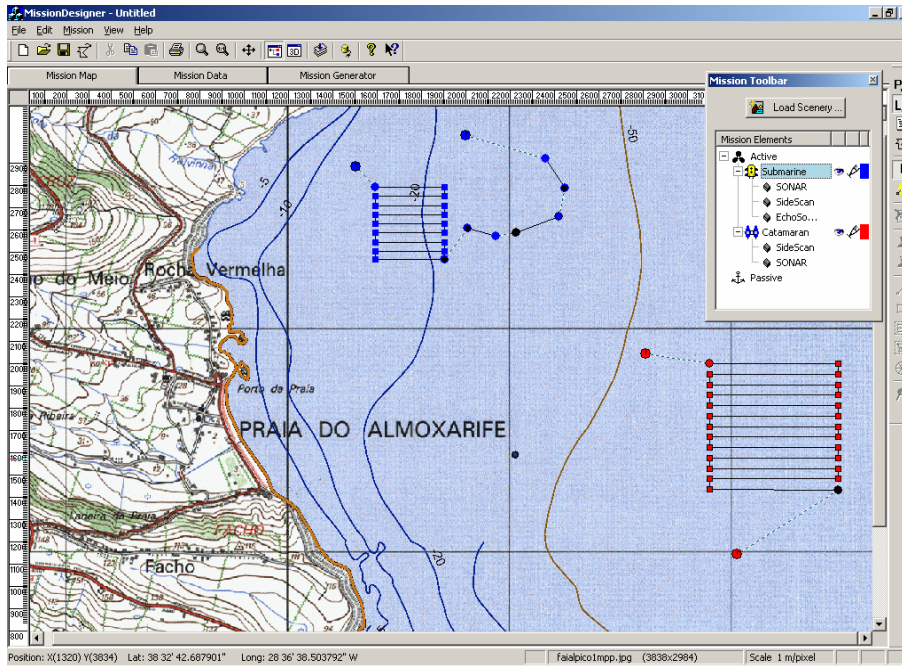

Figure 14. Multiple vehicle mission design: graphical interface

the set-up adopted at IST/ISR, *mission design* and *mission execution* are done seamlessly by resorting to simple, intuitive human/machine interfaces. Missions are simply *designed* in an interactive manner by clicking and dragging over the desired target area maps and selecting items out of menus that contain a list of possible vehicle actions. See Figure 14, which is a printout of a graphical interface for mission design. Notice the presence of a mission map (map of the area to be covered, possibly with the localization of the obstacles to be avoided), together with a menu of the vehicles available to execute the mission that is being designed. Available to a mission designer are the functionalities of each vehicle (including the types of scientific sensors available), a set of mechanisms enforcing spatial / temporal multi-vehicle synchronization, and a path planning application to help in the mission design process (so as to meet adequate spatial /temporal/ energy requirements). The figure shows the situation where an AUV and as ASC must perform lawn mowing maneuvers in different regions of the map.

The process of mission design and mission execution unfolds into four basis steps, see Figure 15. First, the mission is designed using the graphical interface described above. A mission program is automatically generated in Step 2 and compiled in Step 3. Finally, the mission program is sent to the vehicle or fleet of vehicles in Step 4 and run in real-time. During program execution, the human operator follows the progress of the mission using a similar graphical interface, which now shows the trajectories of the vehicles as they become available via the inter-vehicle communications network.

The methodology adopted for Mission Control System design and implementation can be best explained for the case of a single vehicle (Oliveira et al 1998a).



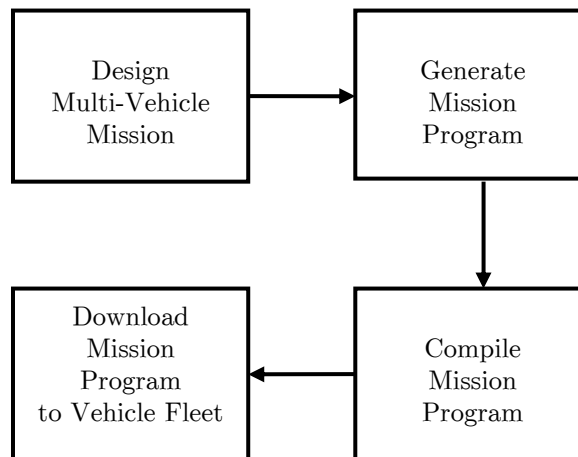

Figure 15. Mission design: automatic program generation

The methodology builds on the key concept of *Vehicle Primitive*, which is a parameterized specification of an elementary operation performed by a marine vehicle (e.g., keeping a constant vehicle speed, maintaining a desired heading, holding a fixed altitude over the seabed, or taking images of the seabed at pre-assigned time instants). Vehicle Primitives are obtained by coordinating the execution of a number of concurrent (*Vehicle*) *System Tasks*, which are parameterized specifications of classes of algorithms or procedures that implement basic functionalities in an underwater robotic system (e.g., the Vehicle Primitive in charge of maintaining a desired heading will require the concerted action of System Tasks devoted to motion sensor data acquisition, navigation and vehicle control algorithm implementation, and actuator control). Vehicle Primitives can in turn be logically and temporally chained to form *Mission Procedures*, aimed at specifying parameterized robot actions at desired abstraction levels. For example, it is possible to recruit the concerted operation of a set of Vehicle Primitives to obtain a parameterized Mission Procedure that will instruct a vehicle to follow an *horizontal path* at a constant speed, depth and heading, for a requested period of time. Mission Procedures allow for modular *Mission Program* generation, and simplify the task of defining new mission plans by modifying/expanding existing ones.

With the methodology adopted, System Task design is carried out using well established tools from continuous/discrete-time dynamic system theory while finite state automata are used to describe the logical interaction between System Tasks and Vehicle Primitives. The design and analysis of Vehicle Primitives, Mission Procedures, and Mission Programs, build on the theory of Petri nets, which are naturally oriented towards the modeling and analysis of asynchronous, discrete event systems with concurrency (Cassandras 1993, Moody 1998). This approach leads naturally to a unifying framework for the analysis of the logical behaviour of the discrete event systems that occur at all levels of a Mission Control System and guarantee basic properties such as the absence of deadlocks.

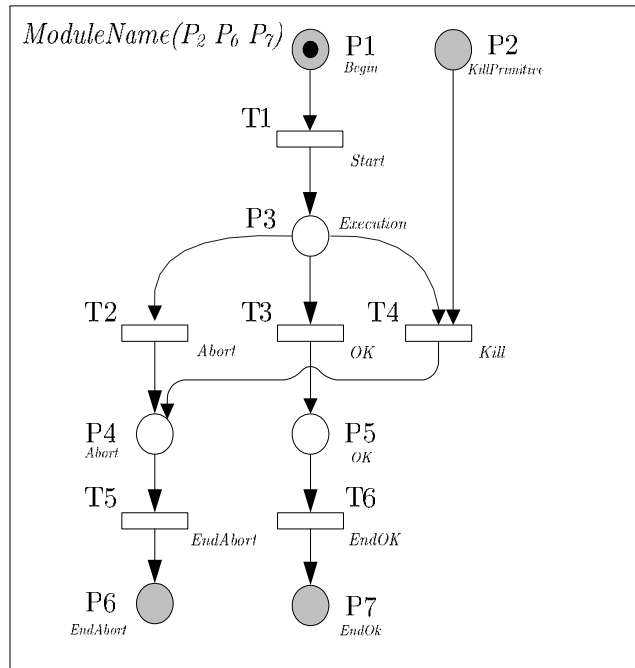

Figure 16. Vehicle Primitive structure

A Mission Program is thus effectively embodied into a - higher level - Petri Net description that supervises the scheduling of Mission Procedures (and thus indirectly of Vehicle Primitives) concurring to the execution of a particular mission. Actual implementation of the building blocks referred to above is done by resorting to a powerful Petri net description language named CORAL (proprietary of IST/ISR) that makes the process depicted in Figure 15 automatic. The extension of these concepts and tools to deal with multi-vehicle operations is described in (Oliveira, 2003).

For the sake of clarity, the basic structure of a Vehicle Primitive, embodied in a Petri net description, is shown in Figure 16. The name of the Primitive is written in “ModuleName”. Notice the presence of places P1, P2, P6, and P7 that play a key role in integrating a particular Vehicle Primitive in the overall Mission program. Placing a mark in P1 enables the execution of the Primitive. A mark in P2 will force the Primitive to abort. A mark in P6 represents the successful execution of the primitive, whereas a mark in P7 means that there was a failure in the execution. The firing of transition T3 is the event required to actually start the execution of the System Tasks that concur to the execution of the Vehicle Primitive.

The Mission Control System developed and tested by IST/ISR using the marine vehicles described in Section 1 is supported by a distributed computer architecture. Distributed processes (both inside a single vehicle or across several vehicles) are coordinated using inter-process/inter-computer communication and synchronization mechanisms implemented over CAN Bus and Ethernet, using Internet Protocol (IP) and other proprietary communication protocols. This distributed computer architecture is designed around PCs (PC104) running the Windows Embedded NT operating system, and around 8 and 16 bit microcontrollers (such as the Siemens C509L and the Philips XAS3) that communicate using a standard Intel 82527

Controller Area Network controller (CAN 2B protocol). All microcontroller boards were developed at IST/ISR with the purpose of meeting stringent requirements on power consumption, reliability, and cost.

#### 4.2 Missions at Sea.

A large series of missions with different types of marine vehicles have consistently shown the reliability of the Mission Control System developed at IST/ISR. The figures that follow illustrate the types of missions and scientific data acquired with the Delfim ASC and the Infante AUV in the Azores, Portugal. Figure 17 (left) shows a bathymetric map of the D. João de Castro Bank seamount (sunken volcano), off the coast of Terceira island, obtained with an echosounder that is part of the scientific equipment of Delfim. The vehicle ran transects over the seamount in a purely autonomous mode. Figure 17 (right) shows echosounder data obtained when moving from the outside to the inside of the crater. The figure captures the contour of the seamount. Notice also the presence of acoustic reflections off the bubbles that occur near the hydrothermal vents located around the rim of the crater. Figure 18 (Left) shows a bathymetric map of a scenario of operation for the Infante AUV, near Faial island, in the Pico canal. A geological fault is clearly seen protruding from the island (not represented, but located at the top of the figure) in the direction of the canal. Fig. 18 (Right) shows sidescan data obtained with Infante AUV while maneuvering at a fixed depth above the fault, crossing it from left to right. The fault is easily identified in the sidescan sonar image.

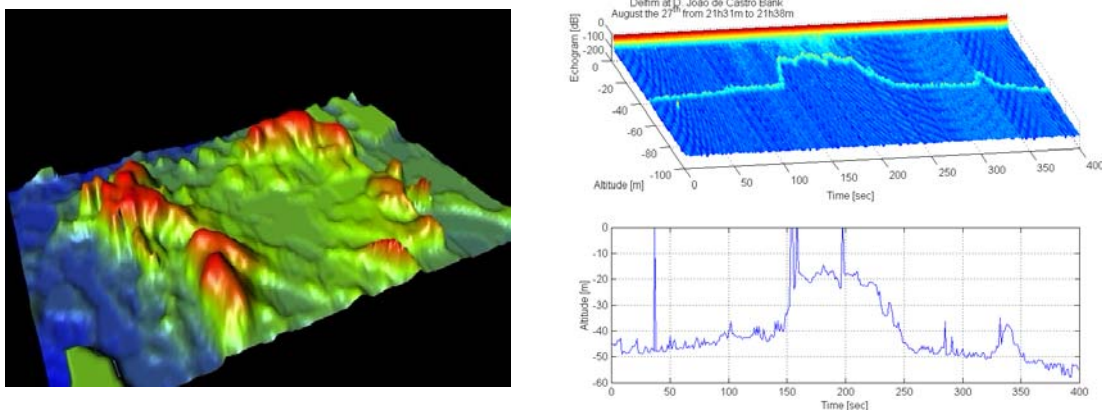

Figure 17. Mission with the Delfim ASC over the D. Joao de Castro seamount. Left - Bathymetric map of the area; Right – echosounder data over the seamount.

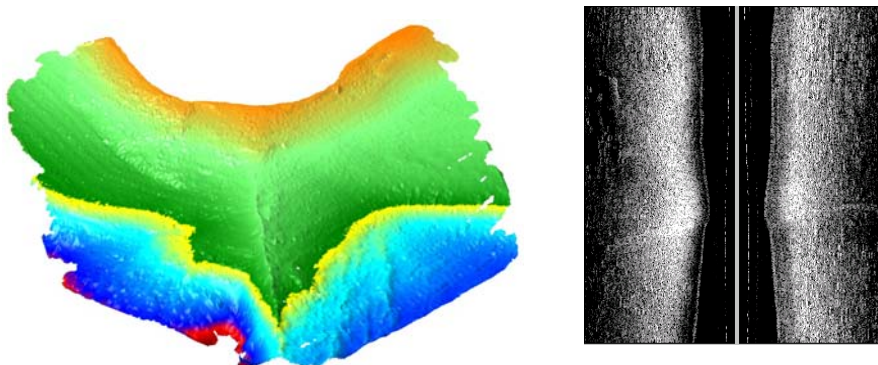

Figure 18. Mission with the Infante AUV over the Espalamaca ridge, Azores. Left - Bathymetric map of the area; Right – sidescan data over the ridge.

## 5. Conclusions

This chapter provided an overview of theoretical and practical problems in the field of marine robotics with a focus on the areas of vehicle and mission control. At the vehicle control level, four categories of problems were introduced: vertical and horizontal plane control, pose control, trajectory tracking and path following, and coordinated motion control of multiple marine robots. Recent advances in linear and nonlinear control theory were shown to provide solid bases for their solution. The technical machinery needed borrows from gain scheduling control theory, linear matrix inequalities, Lyapunov based controller design, backstepping, and graph theory. At the Mission Control level, the chapter called attention to the challenging problem of bringing together time-driven and event-driven systems under a unifying framework. Petri nets were presented as the tool par excellence to tackle this problem, from both an analysis and synthesis viewpoint. To ground the presentation on practical issues, the chapter included the results of tests carried out at sea with prototype autonomous underwater vehicles (AUVs) and autonomous surface craft (ASCs). The picture that emerges is that theory and practice must go hand in hand if one is to develop a future breed of marine vehicles capable of operating reliably at sea in a cooperative manner. The challenging problems of cooperative motion control and navigation under severe communications constraints will certainly guide much of the research in the years to come.

## Acknowledgement

The authors would you like to thank R. Ghabcheloo for his very constructive review of the section on vehicle control and also J. Alves, R. Oliveira, L. Sebastião, and M. Rufino for their valuable assistance in documenting the tests at sea and preparing the section on mission control.

## 6. References

- Aicardi, M., G. Casalino, A. Bicchi, A. Balestrino (1995), "Closed loop steering of unicycle-like vehicles via Lyapunov techniques," *IEEE Robotics and Automation Magazine*, March, pp. 27-35.
- Aicardi, M., G. Casalino, G. Indiveri, A. Aguiar, P. Encarnação, and A. Pascoal (2001), "A planar path following controller for underactuated marine vehicles," *Proc. 9<sup>th</sup> Mediterranean Conference on Control and Automation*, Dubrovnik, Croatia.
- Aguiar, A. and A. Pascoal (1997), "Modeling and control of an autonomous underwater shuttle for the transport of Benthic Laboratories," *Proc. MTS/IEEE OCEANS'97 Conference*, Halifax, NS, Canada.
- Aguiar, A. and A. Pascoal (2001), "Regulation of a nonholonomic autonomous underwater vehicle with parametric modeling uncertainty using Lyapunov functions," *Proc. 40<sup>th</sup> IEEE Conference on Decision and Control*, Orlando, Florida, USA.

Aguiar, A. (2002a). *Nonlinear motion control of nonholonomic and underactuated systems*. PhD Thesis, Instituto Superior Técnico, Lisbon, Portugal.

Aguiar, A. and A. Pascoal (2002b), “Dynamic positioning of an underactuated AUV in the presence of a constant unknown current disturbance,” *Proc. 15<sup>th</sup> IFAC World Congress*, Barcelona, Spain.

Aguiar, A. and A. Pascoal (2002c), “Dynamic positioning and way-point tracking of underactuated AUVs in the presence of ocean currents,” *Proc. 41<sup>st</sup> IEEE Conference on Decision and Control*, Las Vegas, Nevada, USA.

Aguiar, A. and A. Pascoal (2002d), “Stabilization of an underactuated autonomous underwater vehicle via logic-based hybrid control,” *Proc. 10<sup>th</sup> Mediterranean Conference on Control and Automation*, Lisbon, Portugal.

ASIMOV Team (2000), “Robotic ocean vehicles for marine science applications: the European ASIMOV project,” *Proc. OCEANS 2000 MTS /IEEE*, Rhode Island, USA.

Athans, M., S. Fekri, and A. Pascoal (2005), “Issues on Robust Adaptive Feedback Control,” *Plenary Talk, Proc. 16<sup>th</sup> IFAC World Congress*, Prague, Czech Republic.

Bachmayer, R. and N. Leonard (2002), “Vehicle networks for gradient descent in a sampled environment,” *Proc. 41<sup>st</sup> IEEE Conf, Decision and Control*, Las Vegas, Nevada, USA.

Beard, R., J. Lawton, and F. Hadaegh (1999), “A coordination architecture for spacecraft formation control,” *IEEE Trans. Control System Technology*, Vol.9, pp. 777--790.

Bhatta, P. and N. Leonard (2002), “Stabilization and coordination of underwater gliders,” *Proc. 41<sup>st</sup> IEEE Conf. Decision and Control*, Las Vegas, Nevada, USA.

Biggs, N. (1993). *Algebraic Graph Theory*. Second Edition, Cambridge University Press.

Boyd, S., El Gahoui, E. Feron, and V. Balakrishnan (1994). “Linear Matrix Inequalities in Systems and Control Theory,” *Society for Industrial and Applied Mathematics, SIAM*, Philadelphia, USA.

Brisset, L., M. Nokin, D. Semac, H. Amann, W. Schneider, and A. Pascoal (1995), “New methods for deep sea intervention on future benthic laboratories: analysis, development, and testing,” *Proc. Second Mast Days and Euromar Market Conference*, Sorrento, Italy.

Brockett, R. (1983), “Asymptotic stability and feedback stabilization,” In R. Brockett, R. Millman, and H. Sussman, Editors, *Differential Geometric Control Theory*, pp. 181--191, Birkhauser.

Caravela (2001), "Caravela Final Report (in Portuguese)," *Project L-104, PRAXIS XXI, IMAR-Rinave-IST-Conafi*, Lisbon, Portugal.

Cassandras, C. (1993). *Discrete Event Systems, Modelling and Performance Analysis*. Aksen Associates Incorporated Publishers.

Del Rio, F., G. Jimenez, J. Sevillano, C. Amaya, and A. Balcells (2002), "A New Method for Tracking Memorized Paths: Applications to Unicycle Robots," *Proc. MED2002*, Lisbon, Portugal.

Desai, J., J. Otrowski and V. Kumar (1998), "Controlling formations of multiple robots," *Proc. IEEE International Conference on Robotics and Automation*, Leuven, Belgium.

Doyle, J., K. Glover, P. Khargonekar, and B. Francis (1989), "State space solutions to standard  $H_2$  and  $H_\infty$  control problems," *IEEE Transactions on Automatic Control*, Vol. 34, No.8, pp. 831--847.

Egeskov, P., A. Bjerrum, A. Pascoal, C. Silvestre, C. Aage and L. Smitt (1994), "Design, construction and hydrodynamic tests of the AUV MARIUS," *Proc. Symposium on Autonomous Underwater Vehicle Technology*, Cambridge, Massachusetts, USA.

Encarnação, P., A. Pascoal and A. Arcaç (2000a), "Path following for autonomous marine craft," *Proc. 5<sup>th</sup> IFAC Conference on Maneuvering and Control of Marine Crafts (MCMC 2000)*, Aalborg, Denmark.

Encarnação, P., A. Pascoal and A. Arcaç (2000b), "Path following for marine vehicles in the presence of unknown currents," *Proc. SYROCO 2000*, Viena, Austria.

Encarnação, P. and A. Pascoal (2000c), "3-D path following for autonomous underwater vehicles," *Proc. 39<sup>th</sup> IEEE Conference on Decision and Control*, Sydney, Australia.

Encarnação, P. and A. Pascoal (2001a), "Combined trajectory tracking and path following for marine vehicles," *Proc. 9<sup>th</sup> Mediterranean Conference on Control and Automation*, Dubrovnik, Croatia.

Encarnação, P. and A. Pascoal (2001b), "Combined trajectory tracking and path following: an application to the coordinated control of autonomous marine craft," *Proc. 40<sup>th</sup> IEEE Conference on Decision and Control*, Orlando, Florida, USA.

Encarnação, P. (2002). *Nonlinear path following control systems for ocean vehicles*. PhD Thesis, Instituto Superior Técnico, Lisbon, Portugal.

Fax, A. and R. Murray (2002a), "Information flow and cooperative control of vehicle formations," *Proc. 15<sup>th</sup> IFAC World Congress*, Barcelona, Spain.

Fax, A. and R. Murray (2002b), "Graph Laplacians and stabilization of vehicle formations," *Proc. 15<sup>th</sup> IFAC World Congress*, Barcelona, Spain.

Fossen, T. (2002). *Marine Control Systems: Guidance, Navigation and Control of Ships, Rigs and Underwater Vehicles*. Marine Cybernetics AS, Trondheim, Norway.

Ghabcheloo, R., A. Pascoal, C. Silvestre and I. Kaminer (2004a), "Coordinated path following control of multiple wheeled robots," *Proc. 5<sup>th</sup> IFAC Symposium on Intelligent Autonomous Vehicles*, Lisbon, Portugal. To appear in *International Journal of Systems Science: Special Issue on Cooperative Control Approaches for Multiple Mobile Robots*, 2005.

Ghabcheloo, R., A. Pascoal, C. Silvestre and I. Kaminer (2004b), "Coordinated path following control using linearization techniques," *Internal Report, Code CPF01-2004*, Institute for Systems and Robotics, Lisbon, Portugal.

Ghabcheloo, R., A. Pascoal and C. Silvestre (2004c), and I. Kaminer, "Coordinated path following control using nonlinear techniques," *Internal Report, Code CPF02-2004*, Institute for Systems and Robotics, Lisbon, Portugal.

Ghabcheloo, R., A. Pascoal and C. Silvestre (2005a), "Nonlinear coordinated path following control of multiple wheeled robots with communication constraints," *Proc. ICAR 2005*, Seattle, Washington, USA.

Ghabcheloo, R., D. Carvalho and A. Pascoal (2005b), "Coordinated motion control of fully actuated underwater vehicles," *Internal Report, Code CPFUV01-2005*, Institute for Systems and Robotics, Lisbon, Portugal.

Giulletti, F., L. Pollini and M. Innocenti (2000), "Autonomous formation flight," *IEEE Control Systems Magazine*, Vol. 20, No. 6, pp. 34–44.

Hallberg, E., I. Kaminer and A. Pascoal (1999), "Development of a rapid flight test prototyping system for unmanned air vehicles," *IEEE Control Systems Magazine*, Vol. 19, No.1, pp. 55–65.

Hauser, J. and R. Hindman (1995), "Maneuver regulation from trajectory tracking: Feedback linearizable systems," *Proc. IFAC Symp. On Nonlinear Control Systems Design*, Lake Tahoe, CA, USA.

Healey, A. and D. Lienard (1993), "Multivariable sliding mode control for autonomous diving and steering of unmanned underwater vehicles," *IEEE Journal of Ocean Engineering*, Vol. 18, No.3, pp. 327–339.

Healey, A., D. Marco, P. Oliveira, A. Pascoal, C. Silvestre, and V. Silva (1996a), "Strategic level mission control and evaluation of CORAL and PROLOG implementations for mission control specifications," *Proc. IEEE Autonomous Underwater Vehicle (AUV) 96 Conference*, Monterey, CA, USA.

Healey, A., D. Marco, and R. McGhee (1996b), "Autonomous underwater vehicle control coordination using a tri-level hybrid software architecture," *Proc. of the IEEE Robotics and Automation Conference*, Minneapolis, USA.

Jadbabaie, A., J. Lin and A. S. Morse (2003), "Coordination of groups of mobile autonomous agents using nearest neighbor rules," *IEEE Transactions on Automatic Control*, Vol. 48, No. 6, pp. 988--1001.

Kaminer, I., A. Pascoal, P. Khargonekar and E. Coleman (1995), "A velocity algorithm for the implementation of gain-scheduled controllers", *Automatica*, Vol. 31, No.8, pp. 1185--1191.

Kaminer, I., A. Pascoal, E. Hallberg and C. Silvestre (1998), "Trajectory tracking for autonomous vehicles: an integrated approach to guidance and control," *Journal Of Guidance, Control, and Dynamics*, Vol. 21, No.1, pp. 29--38.

Kaminer, I., A. Pascoal and O. Yakimenko (2005), "Nonlinear path following control of fully actuated marine vehicles with parameter uncertainty," *Proc. 16<sup>th</sup> IFAC World Congress*, Prague, Czech Republic.

Khalil, H. K. (2000). *Nonlinear Systems*. Third Edition, Pearson Education International, Inc. New Jersey.

Krstic, M., I. Kanellakopoulos, and P. Kokotovic (1995). *Nonlinear and Adaptive Control Design*. John Wiley & Sons, Inc., New York.

Kyrkjebo and K. Pettersen (2003), "Ship replenishment using synchronization control," *Proc. 6<sup>th</sup> IFAC Conference on Manoeuvring and Control of Marine Craft*, Girona, Spain.

Kyrkjebo, M. Wondergem, K. Pettersen, and H. Nijmeijer (2004), "Experimental results on synchronization control of ship rendez-vous operations," *Proc. IFAC Conference on Control Applications in Marine Systems*, Ancona, Italy.

Lapierre, L., D. Soetanto and A. Pascoal (2003a), "Nonlinear path following control of autonomous underwater vehicles," *Proc. IFAC Workshop on Guidance and Control of Underwater Vehicles*, Newport, South Wales, UK.

Lapierre, L., D. Soetanto, and A. Pascoal (2003b), "Coordinated motion control of marine robots," *Proc. 6<sup>th</sup> IFAC Conference on Manoeuvring and Control of Marine Craft*, Girona, Spain.

Mesbahi, M. and F. Hadaegh (2001), "Formation flying control of multiple spacecraft via graphs, matrix inequalities, and switching," *Journal of Guidance, Control and Dynamics*, Vol. 24, No. 2, pp. 369--377.

Micaelli, A. and C. Samson (1993), "Trajectory-tracking for unicycle-type and two-steering-wheels mobile robots," *Technical Report No. 2097, Project Icare*, INRIA, Sophia-Antipolis, France.



Moody, J. and Antsaklis, P. (1998) *Supervisory Control of Discrete Event Systems Using Petri Nets*, Kluwer Academic Publishers.

Mureau, L. (2005), "Stability of multiagent systems with time-dependent communication links," *IEEE Transactions on Automatic Control*, Vol. 50, No. 2, pp. 169--182.

Olfati Saber, R. and R. Murray (2003), "Agreement problems in networks with directed graphs and switching topology," *Proc. 42<sup>nd</sup> IEEE Conference on Decision and Control*, Hawaii, USA.

Ogren, P., M. Egerstedt and X. Hu (2002), "A control Lyapunov function approach to multiagent coordination," *IEEE Trans. on Robotics and Automation*, Vol. 18, No. 5, pp. 847--851.

Oliveira P., A. Pascoal, V. Silva, and C. Silvestre (1996), "Design, development, and testing of a mission control system for the MARIUS AUV," *Proc. 6<sup>th</sup> International Advanced Robotics Program IARP-96*, Toulon, France.

Oliveira, P., A. Pascoal, V. Silva and C. Silvestre (1998a), "Mission control of the MARIUS autonomous underwater vehicle: system design, implementation, and sea trials," *International Journal of Systems Science, Special Issue on Underwater Robotics*, Vol. 29, No. 10, pp. 1065--1080.

Oliveira, P., C. Silvestre, A. Pascoal and A. Aguiar (1998b), "Vehicle and mission control of the SIRENE underwater shuttle," *Proc. IFAC Conference on Control Applications in Marine Systems*, Fukuoka, Japan.

Oliveira, P., C. Silvestre, P. Aguiar and A. Pascoal (1998c), "Guidance and control of the SIRENE underwater shuttle: from system design to tests at sea," *Proc. OCEANS'98 Conference*, Toulon, France.

Oliveira, P. (2002). *Periodic and nonlinear estimators with applications to the navigation of ocean vehicles*. PhD Thesis, Instituto Superior Técnico, Lisbon, Portugal.

Oliveira, R. (2003). *Supervision and mission control of autonomous vehicles*, MSc Thesis (in Portuguese), Instituto Superior Técnico, Lisbon, Portugal.

Pascoal, A., C. Silvestre, P. Oliveira, A. Bjerrum, G. Ayela, J. Paul-Pignon, S. Bruun and C. Petzelt (1997), "MARIUS: an autonomous underwater vehicle for coastal oceanography," *IEEE Robotics and Automation Magazine*, Special Issue on Robotics and Automation in Europe: Projects funded by the Commission of the European Union, Vol. 4, No.4, pp. 46--59.

Prado, M. (2005). *Modeling and Control of an Autonomous Oceanographic Vessel*. MSc Thesis (in Portuguese), Instituto Superior Técnico, Lisbon, Portugal.

- Pratcher, M., J. D'Azzo and A. Proud (2001), "Tight formation control," *Journal of Guidance, Control and Dynamics*, Vol. 24, No. 2, pp. 246--254.
- Queiroz, M., V. Kapila and Q. Yan (2000), "Adaptive nonlinear control of multiple spacecraft formation flying," *Journal of Guidance, Control and Dynamics*, Vol. 23, No.3, pp. 385--390.
- Rouche, N., P. Habets and M. Laloy (1993). *Stability theory by Liapunov's direct method*. Springer-Verlag New York, Inc.
- Rugh, W. and J. S. Shamma (2000), "A survey of research on gain- scheduling," *Automatica*, September, pp. 1401--1425.
- Samson, C. (1992), "Path following and time-varying feedback stabilization of a wheeled mobile robot," *Proc. ICAARCV 92 Conference*, Singapore.
- Silvestre, C. and A. Pascoal (1997a), "Control of an AUV in the vertical and horizontal planes: system design and tests at sea," *IEE Transactions of the Institute of Measurement and Control*, Vol. 19, No. 3, pp. 126--138.
- Silvestre, C. and A. Pascoal (1997b), "AUV control under wave disturbances," *Proc. 10<sup>th</sup> International Symposium on Unmanned Untethered Submersible Technology*, New Hampshire, USA.
- Silvestre, C. (2000). *Multi-objective optimization theory with applications to the integrated design of controllers / plants for underwater vehicles*. PhD Thesis, Instituto Superior Técnico, Lisbon, Portugal.
- Silvestre, C., A. Pascoal and I. Kaminer (2002), "On the design of gain-scheduled trajectory tracking controllers," *International Journal of Robust and Nonlinear Control*, Vol. 12, No. 9, pp. 797--839.
- Silvestre, C. and A. Pascoal (2004), "Control of the Infante AUV using gain-scheduled static output feedback," *IFAC Journal Control Engineering Practice*, Vol. 12 No.12, pp. 1501--1509.
- Silvestre, C. and A. Pascoal (2005), "Depth control of the Infante AUV using gain-scheduled reduced-order output feedback," *Proc. 16<sup>th</sup> IFAC World Congress*, Prague, Czech Republic, 2005.
- Skjetne, R., S. Moi and T. Fossen (2002a), "Nonlinear formation control of marine craft," *Proc. 41<sup>st</sup> IEEE Conf. on Decision and Control*, Las Vegas, NV, USA.
- Skjetne, R., A. Teel and P. Kokotovic (2002b), "Stabilization of sets parametrized by a single variable: application to ship maneuvering," *Proc. 15<sup>th</sup> Int. Symposium on Mathematical Theory of Network Science*, Notre Dame, IN, USA.
- Skjetne, R., I. Flakstad and T. Fossen (2003), "Formation control by synchronizing multiple maneuvering systems," *Proc. 6<sup>th</sup> IFAC Conference on Maneuvering and Control of Marine Craft*, Girona, Spain.

Skjetne, R., T. Fossen, and P. Kokotovic (2004), "Robust output maneuvering for a class of nonlinear systems," *Automatica*, Vol. 40, pp. 373--383.

Soetanto, D., L. Lapierre and A. Pascoal (2003), "Adaptive nonsingular path following control of wheeled robots," *Proc. 42<sup>nd</sup> IEEE Conference on Decision and Control*, Hawaii, USA.

Stilwell, D. and B. Bishop (2000), "Platoons of underwater vehicles," *IEEE Control Systems Magazine*, Vol. 20, No. 6, pp. 45--52.